

LECTURE NOTES
ON
CONTROL SYSTEMS
6TH SEMESTER

PREPARED BY :-
PRABHUDATTA PUJAPANDA
(LECTURER IN ELECTRICAL ENGINEERING)



GOVT. POLYTECHNIC SONEPUR



(Autonomous)

Dundigal, Hyderabad - 500043

UNIT - I

INTRODUCTION AND MODELING OF PHYSICAL SYSTEMS

1.1 Basic elements of control system

In recent years, control systems have gained an increasingly importance in the development and advancement of the modern civilization and technology. Figure shows the basic components of a control system. Disregard the complexity of the system; it consists of an input (objective), the control system and its output (result). Practically our day-to-day activities are affected by some type of control systems. There are two main branches of control systems: 1) Open-loop systems and

2) Closed-loop systems.

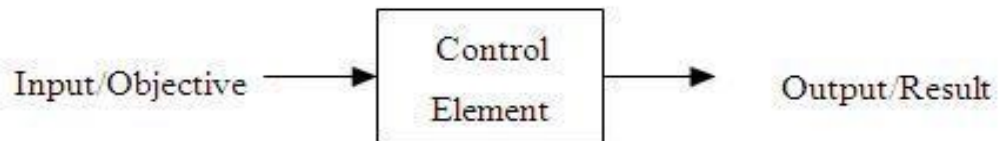

Basic Components of Control System

1.2 Open-loop systems:

The open-loop system is also called the non-feedback system. This is the simpler of the two systems. A simple example is illustrated by the speed control of an automobile as shown in Figure 1-2. In this open-loop system, there is no way to ensure the actual speed is close to the desired speed automatically. The actual speed might be way off the desired speed because of the wind speed and/or road conditions, such as uphill or downhill etc.

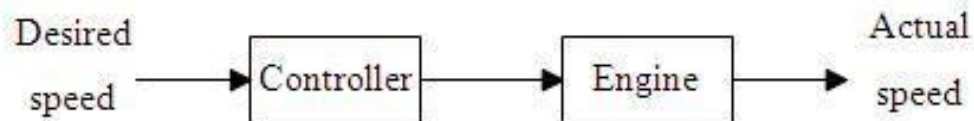

Basic Open Loop System

Closed -loop systems:

The closed-loop system is also called the feedback system. A simple closed-system is shown in Figure 1-3. It has a mechanism to ensure the actual speed is close to the desired speed automatically.

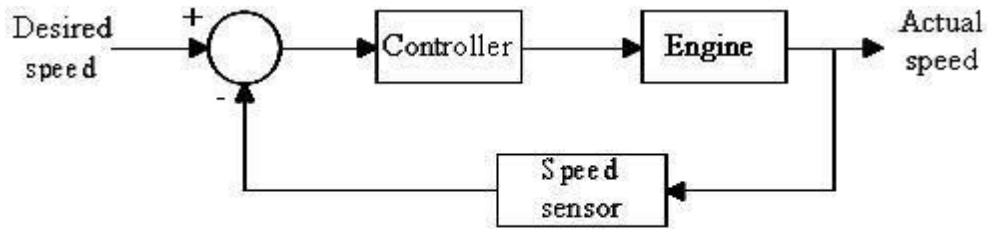

1.3

Fig 1-3. Basic closed-loop system.

Mechanical Translational systems

The model of mechanical translational systems can obtain by using three basic elements mass, spring and dashpot. When a force is applied to a translational mechanical system, it is opposed by opposing forces due to mass, friction and elasticity of the system. The force acting on a mechanical body is governed by Newton's second law of motion. For translational systems it states that the sum of forces acting on a body is zero.

Force balance equations of idealized elements:

Consider an ideal mass element shown in fig. which has negligible friction and elasticity. Let a force be applied on it. The mass will offer an opposing force which is proportional to acceleration of a body.

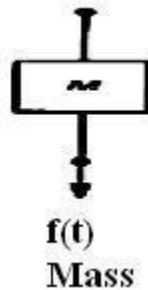

Let f = applied force

f_m = opposing force due to mass

Here $f_m \propto M \frac{d^2 x}{dt^2}$

By Newton's second law, $f = f_m = M \frac{d^2 x}{dt^2}$

Consider an ideal frictional element dash-pot shown in fig. which has negligible mass and elasticity. Let a force be applied on it. The dashpot will offer an opposing force which is proportional to velocity of the body.

Let $f =$ applied force $f_b =$ opposing force due to friction Here, $f_b \propto B \frac{dx}{dt}$

By Newton's second law, $f = f_b = M \frac{dx}{dt}$
 Consider an ideal elastic element spring negligible mass and friction.

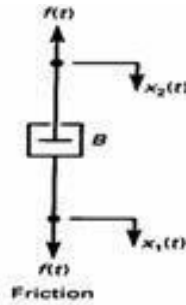

$\frac{dx}{dt}$ is shown in fig. This has

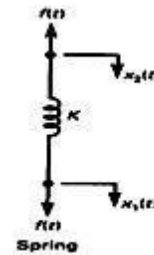

Let $f =$ applied force
 $f_k =$ opposing force due to elasticity

Here, $f_k \propto x$
 By Newton's second law, $f = f_k = kx$

Mechanical Rotational Systems:

The model of rotational mechanical systems can be obtained by using three elements, moment of inertia [J] of mass, dash pot with rotational frictional coefficient [B] and torsional spring with stiffness[k].

When a torque is applied to a rotational mechanical system, it is opposed by opposing torques due to moment of inertia, friction and elasticity of the system. The torque acting on rotational mechanical bodies is governed by Newton's second law of motion for rotational systems.

Torque balance equations of idealized elements

Consider an ideal mass element shown in fig. which has negligible friction and elasticity. The opposing torque due to moment of inertia is proportional to the angular acceleration.

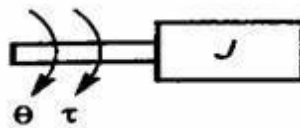

Let $T =$ applied torque
 $T_j =$ opposing torque due to moment of inertia of the body

Here $T_j = \alpha J \frac{d\theta}{dt}$

By Newton's law

$T = T_j = J \frac{d\theta}{dt}$

Consider an ideal frictional element dash pot shown in fig. which has negligible moment of inertia and elasticity. Let a torque be applied on it. The dash pot will offer an opposing torque is proportional to angular velocity of the body.

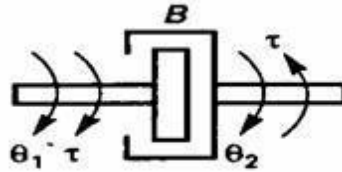

Let T = applied torque

T_b = opposing torque due to friction

Here $T_b = \alpha B \frac{d}{dt} (\theta_1 - \theta_2)$

By Newton's law

$T = T_b = B \frac{d}{dt} (\theta_1 - \theta_2)$

. Consider an ideal elastic element, torsional spring as shown in fig. which has negligible moment of inertia and friction. Let a torque be applied on it. The torsional spring will offer an opposing torque which is proportional to angular displacement of the body



Let T = applied torque

T_k = opposing torque due to friction

Here $T_k \propto K (\theta_1 - \theta_2)$

By Newton's law

$T = T_k = K (\theta_1 - \theta_2)$

Modeling of electrical system

- Electrical circuits involving resistors, capacitors and inductors are considered. The behaviour of such systems is governed by Ohm's law and Kirchhoff's laws
- Resistor: Consider a resistance of $R \Omega$ carrying current i Amps as shown in Fig (a), then the voltage drop across it is $v = R I$

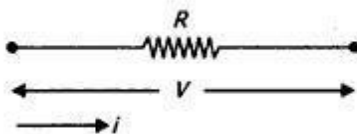

- **Inductor:** Consider an inductor L H carrying current i Amps as shown in Fig (a), then the voltage drop across it can be written as $v = L \frac{di}{dt}$

- **Capacitor:** Consider a current i Amps as shown

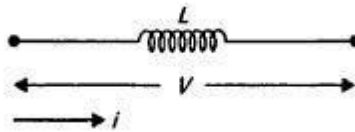

capacitor C F carrying in Fig (a), then

the voltage drop across it can be written as $v = (1/C) \int i dt$

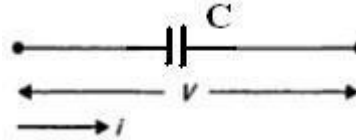

Steps for modeling of

- Apply Kirchoff's voltage law to form the differential equations describing electrical circuits comprising of resistors, capacitors, and inductors.
- Form Transfer Functions from the describing differential equations. Then
- simulate the model.

electrical system

law or Kirchoff's current law

Example

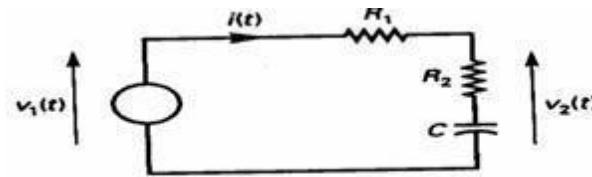

$$R_1 i(t) + R_2 i(t) + 1/C \int i(t) dt = V_1(t)$$

$$R_2 i(t) + 1/C \int i(t) dt = V_2(t)$$

Electrical systems LRC circuit. Applying Kirchoff's voltage law to the system shown. We obtain the following equation;

Resistance circuit

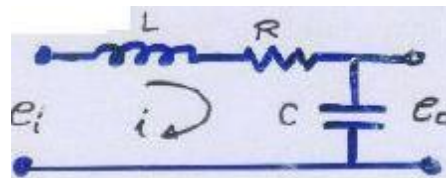

$$L(di/dt) + Ri + 1/C \int i(t) dt = e_i \dots\dots\dots (1)$$

$$1/C \int i(t) dt = e_o \dots\dots\dots (2)$$

Equation (1) & (2) give a mathematical model of the circuit. Taking the L.T. of equations (1)&(2) , assuming zero initial conditions, we obtain

$$LsI(s) + RI(s) + \frac{1}{C} \frac{1}{s} I(s) = E_i(s)$$

$$\frac{1}{C} \frac{1}{s} I(s) = E_o(s)$$

the transfer function $\frac{E_o(s)}{E_i(s)} = \frac{1}{LCs^2 + RCs + 1}$

Armature Controlled motors

-
dc

The dc motors have separately excited fields. They are either armature-controlled with fixed field or field-controlled with fixed armature current. For example, dc motors used in instruments employ a fixed permanent-magnet field, and the controlled signal is applied to the armature terminals.

Consider the armature -controlled dc motor shown in the following figure.

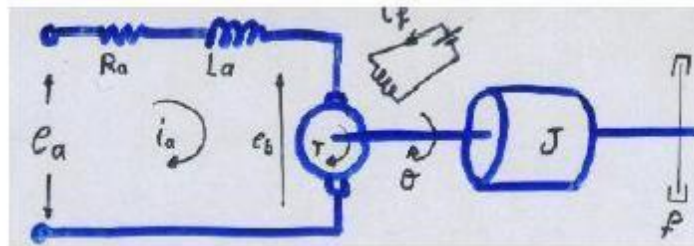

Ra = armature-winding resistance, ohms

La = armature-winding inductance, henrys

ia = armature-winding current, amperes

ea = applied armature voltage, volts
eb = back emf, volts

θ = angular displacement of the motor shaft, radians

T = torque delivered by the motor, Newton*meter

J = equivalent moment of inertia of the motor and load referred to the motor shaft kg.m²

f = equivalent viscous-friction coefficient of the motor and load referred to the motor shaft. Newton*m/rad/s

T = k_t i_a ψ where ψ is the air gap flux, ψ = k_f i_f, k_t is constant

For the constant flux

$$e_b = k_b \frac{d\theta}{dt}$$

Where K_b is a back emf constant ----- (1)

The differential equation for the armature circuit

$$L_a \frac{di_a}{dt} + R_a i_a + e_b = e_a \dots\dots\dots(2)$$

The armature current produces the torque which is applied to the inertia and friction; hence

$$\frac{Jd^2\theta}{dt^2} + f \frac{d\theta}{dt} = T = K i_a \dots \dots (3)$$

Assuming that all initial conditions are condition are zero/and taking the L.T. of equations (1),

(2) & (3), we obtain Kps

$$\theta(s) = E_b(s)$$

$$(L_a s + R_a) I_a(s) + E_b(s) = E_a(s) \quad (J s^2 + f s)$$

$\theta(s) = T(s) = K I_a(s)$ The T.F can be obtained is

$$\frac{\theta(s)}{E_a(s)} = \frac{K}{s(L_a J s^2 + (L_a f + R_a J)s + R_a f + K K_b)}$$

Analogous Systems

Let us consider a mechanical (both translational and rotational) and electrical system as shown in the fig.

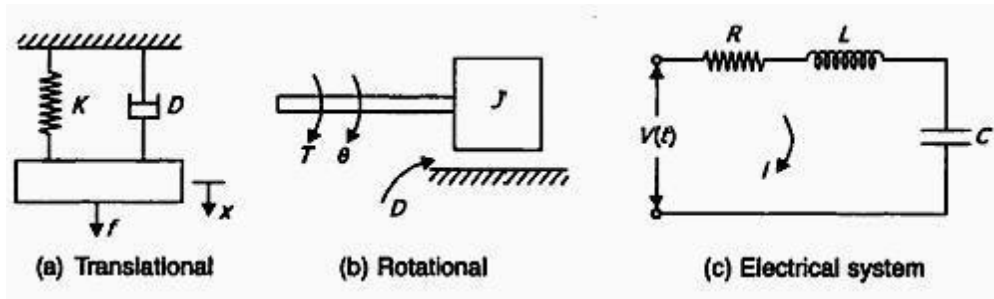

From the fig (a)

$$M \frac{d^2 x}{dt^2} + D \frac{dx}{dt} + K x = f$$

From the fig (b)

$$J \frac{d^2 \theta}{dt^2} + D \frac{d\theta}{dt} + K \theta = T$$

From the fig (c)

$$L \frac{d^2 q}{dt^2} + R \frac{dq}{dt} + \frac{1}{C} q = V(t)$$

Where $q = \int i dt$

They are two methods to get analogous system. These are (i) force- voltage (f-v) analogy and (ii) force -current (f-c) analogy

Translational	Electrical	Rotational
Force (f)	Voltage (v)	Torque (T)
Mass (M)	Inductance (L)	Inertia (J)
Damper (D)	Resistance (R)	Damper (D)
Spring (K)	Elastance $\left(\frac{1}{C}\right)$	Spring (K)
Displacement (x)	Charge (q)	Displacement (θ)
Velocity (u)	Current (i)	Velocity (ω)

Force – Voltage Analogy

Force – Current Analog

Translational	Electrical	Rotational
Force (f)	Current (i)	Torque (T)
Mass (M)	Capacitance (C)	Inertia (J)
Spring (K)	Reciprocal of Inductance $\left(\frac{1}{L}\right)$	Damper (D)
Damper (D)	Conductance $\left(\frac{1}{K}\right)$	Spring (K)
Displacement (x)	Flux Linkage (ψ)	Displacement (θ)
Velocity $\left(u = \frac{dx}{dt}\right)$	Voltage ($v = \frac{d\psi}{dt}$)	Velocity $\left(\omega = \frac{d\theta}{dt}\right)$

Problem

- Find the system equation for system shown in the fig. And also determine f-v and f-i analogies

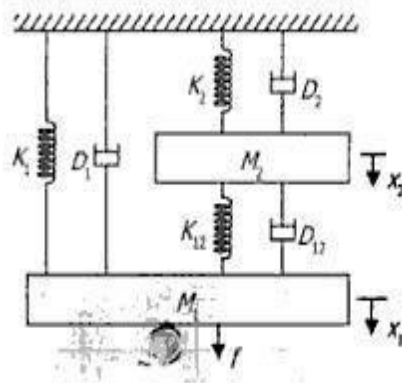

For free body diagram M1

$$f = M_1 \frac{d^2 x_1}{dt^2} + D_1 \frac{dx_1}{dt} + K_1 x_1 + D_{12} \frac{d}{dt} (x_1 - x_2) + K_{12} (x_1 - x_2) \quad (1)$$

For free body diagram M2

$$K_{12} (x_1 - x_2) + D_{12} \frac{d}{dt} (x_1 - x_2) = M_2 \frac{d^2 x_2}{dt^2} + D_2 \frac{dx_2}{dt} + K_2 x_2 \quad (2)$$

Force -voltage analogy

$$f \rightarrow v, M \rightarrow L, D \rightarrow R, K \rightarrow \frac{1}{C}, x \rightarrow q$$

From eq (1) we get

$$v = L_1 \frac{d^2 q_1}{dt^2} + R_1 \frac{dq_1}{dt} + \frac{1}{C_1} q_1 + R_{12} \frac{d}{dt} (q_1 - q_2) + \frac{1}{C_{12}} (q_1 - q_2)$$

$$v = L_1 \frac{di_1}{dt} + R_1 i_1 + \frac{1}{C_1} \int i_1 dt + R_{12} (i_1 - i_2) + \frac{1}{C_{12}} \int (i_1 - i_2) dt \quad (3)$$

From eq (2) we get

$$\frac{1}{C_{12}} (q_1 - q_2) + R_{12} \frac{d}{dt} (q_1 - q_2) = L_2 \frac{d^2 q_2}{dt^2} + R_2 \frac{dq_2}{dt} + \frac{1}{C_2} q_2$$

$$\frac{1}{C_{12}} \int (i_1 - i_2) dt + R_{12} (i_1 - i_2) = L_2 \frac{di_2}{dt} + R_2 i_2 + \frac{1}{C_2} \int i_2 dt$$

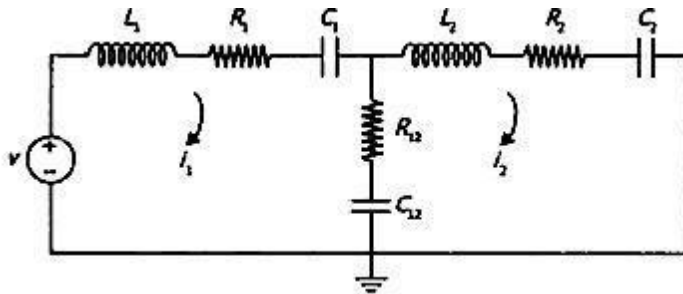

.....(4) From eq (3) and (4) we can draw force-voltage analogy

Force -current analogy

$$f \rightarrow i, M \rightarrow C, D \rightarrow \frac{1}{R}, K \rightarrow \frac{1}{L}, x \rightarrow \psi$$

From eq (1) we get

$$i = C_1 \frac{d^2 \psi_1}{dt^2} + \frac{1}{R_1} \frac{d\psi_1}{dt} + \frac{1}{L_1} \psi_1 + \frac{1}{R_{12}} \frac{d}{dt} (\psi_1 - \psi_2) + \frac{1}{L_{12}} (\psi_1 - \psi_2)$$

$$i = C_1 \frac{dv_1}{dt} + \frac{1}{R_1} v_1 + \frac{1}{L_1} \int i_1 dt + \frac{v_1 - v_2}{R_{12}} + \frac{1}{L_{12}} \int (v_1 - v_2) dt$$

.....(5) From eq (2) we get

$$\frac{1}{L_{12}}(\psi_1 - \psi_2) + \frac{1}{R_{12}} \frac{d}{dt}(\psi_1 - \psi_2) = C_2 \frac{d^2 \psi_2}{dt^2} + \frac{1}{R_2} \frac{d\psi_2}{dt} + \frac{1}{L_{12}} \psi_2$$

$$\frac{1}{L_{12}} \int (v_1 - v_2) dt + \frac{1}{R_{12}} (v_1 - v_2) = C_2 \frac{dv_2}{dt} + \frac{v_2}{R_2} + \frac{1}{L_{12}} \int v_2 dt$$

.....(6)

From eq (5) and (6) we can draw force-current analogy

The system can
in two forms:

- Block
-

Signal flow

1.4 Transfer

- A simpler element maybe governed by first order or second order differential equation. When several elements are connected in sequence, say —n elements, each one with first order, the total order of the system will be nth order
- In general, a collection of components or system shall be represented by nth order differential equation.

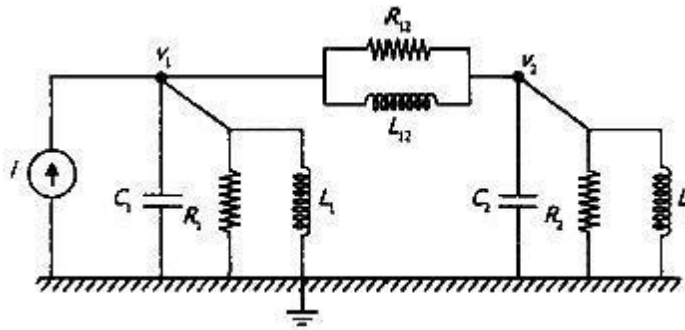

be represented

diagram
representation
graph

Function

system or

- In control systems, transfer function characterizes the input output relationship of components or systems that can be described by Liner Time Invariant Differential Equation
- In the earlier period, the input output relationship of a device was represented graphically.

- In a system having two or more components in sequence, it is very difficult to find graphical relation between the input of the first element and the output of the last element. This problem is solved by transfer function

Definition of Transfer Function:

Transfer function of a LTIV system is defined as the ratio of the Laplace Transform of the output variable to the Laplace Transform of the input variable assuming all the initial condition as zero.

Properties of Transfer Function:

- The transfer function of a system is the mathematical model expressing the differential equation that relates the output to input of the system.
- The transfer function is the property of a system independent of magnitude and the nature of the input.
- The transfer function includes the transfer functions of the individual elements. But at the same time, it does not provide any information regarding physical structure of the system.
- The transfer functions of many physically different systems shall be identical.
- If the transfer function of the system is known, the output response can be studied for various types of inputs to understand the nature of the system.
- If the transfer function is unknown, it may be found out experimentally by applying known inputs to the device and studying the output of the system.

How

you can obtain the transfer function (T. F.): Write

- the differential equation of the system.
- Take the L. T. of the differential equation, assuming all initial condition to be zero. Take the ratio of the output to the input. This ratio is the T. F.

Mathematical Model of control systems

A control system is a collection of physical object connected together to serve an objective. The mathematical model of a control system constitutes a set of differential equation.

1.5 Synchros

A commonly used error detector of mechanical positions of rotating shafts in AC control systems is the Synchro.

It consists of two electro mechanical devices.

- Synchro transmitter
- Synchro receiver or control transformer.

The principle of operation of these two devices is same but they differ slightly in their construction.

- The construction of a Synchro transmitter is similar to a phase alternator.
- The stator consists of a balanced three phase winding and is star connected.
- The rotor is of dumbbell type construction and is wound with a coil to produce a magnetic field.
- When a no voltage is applied to the winding of the rotor, a magnetic field is produced.
- The coils in the stator link with this sinusoidal distributed magnetic flux and voltages are induced in the three coils due to transformer action.
- Than the three voltages are in time phase with each other and the rotor voltage.
- The magnitudes of the voltages are proportional to the cosine of the angle between the rotor position and the respective coil axis.

- The position of the rotor and the coils are shown in Fig.

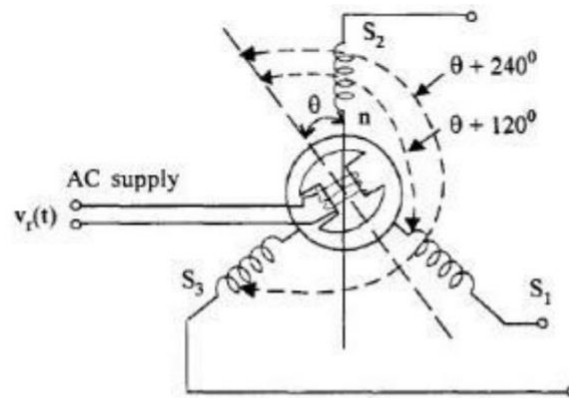

$$v_R(t) = v_r \sin \omega_r t$$

$$v_{s_1n} = KV_r \sin \omega_r t \cos (\theta + 120)$$

$$v_{s_2n} = KV_r \sin \omega_r t \cos \theta$$

$$v_{s_3n} = KV_r \sin \omega_r t \cos (\theta + 240)$$

$$v_{s_1s_2} = v_{s_1n} - v_{s_2n} = \sqrt{3} KV_r \sin (\theta + 240) \sin \omega_r t$$

$$v_{s_2s_3} = v_{s_2n} - v_{s_3n} = \sqrt{3} KV_r \sin (\theta + 120) \sin \omega_r t$$

$$v_{s_3s_1} = v_{s_3n} - v_{s_1n} = \sqrt{3} KV_r \sin \theta \sin \omega_r t$$

- When $\theta = 0^\circ$ the axis of the magnetic field coincides with the axis of coil S2 and maximum voltage is induced in it as seen.
- For this position of the rotor, the voltage e_r is zero, this position of the rotor is known as the 'Electrical Zero' of the transmitter and is taken as reference for specifying the rotor position.
- In summary, it can be seen that the input to the transmitter is the angular position of the rotor and the set of three single phase voltages is the output.
- The magnitudes of these voltages depend on the angular position of the rotor as given

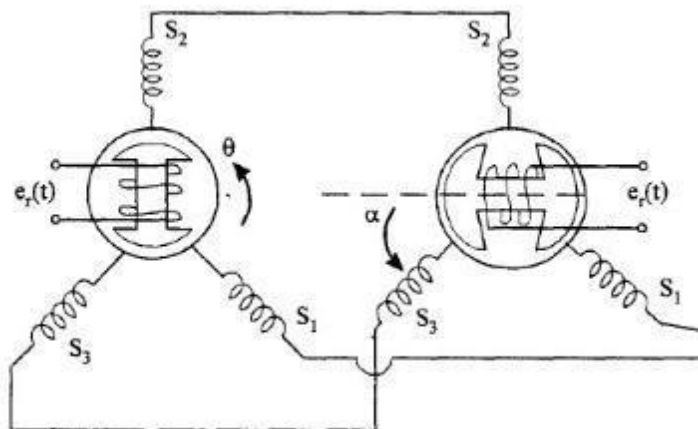

Hence

$$e_r(t) = K_1 V_r \cos \phi \sin \omega_r t$$

Now consider these three voltages to be applied to the stator of a similar device called control transformer or synchro receiver.

- The construction of a control transformer is similar to that of the transmitter except that the rotor is made cylindrical in shape whereas the rotor of transmitter is dumbbell in shape.
- Since the rotor is cylindrical, the air gap is uniform and the reluctance of the magnetic path is constant.
 - This makes the output impedance of rotor to be a constant.
 - Usually the rotor winding of control transformer is connected to an amplifier which requires a signal with constant impedance for better performance.
- A synchro transmitter is usually required to supply several control transformers and hence the stator winding of control transformer is wound with higher impedance per phase.
- Since the same currents flow through the stators of the synchro transmitter and receiver, the same pattern of flux distribution will be produced in the air gap of the control transformer.
- The control transformer flux axis is in the same position as that of the synchro transmitter.
- Thus the voltage induced in the rotor coil of control transformer is proportional to the cosine of the angle between the two rotors.

1.6 AC Servo Motors

- The schematic of a two phase or servo motor is shown

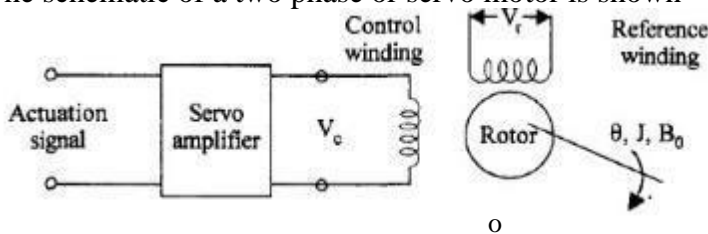

- An AC servo motor is essentially a two phase induction motor with modified constructional features to suit servo applications.

It has two windings displaced by 90° on the stator. One winding, called as reference winding, is supplied with a constant sinusoidal voltage.

- The second winding, called control winding, is supplied with a variable control voltage which is displaced by ± 90° out of phase from the reference voltage.

The major differences between the normal induction motor and an AC servo motor are

- The rotor winding of an AC servo motor has high resistance (R) compared to its inductive reactance (X) so that its X / R ratio is very low.

- For a normal induction motor, X / R ratio is high so that the maximum torque is obtained in normal operating region which is around 5% of slip.
- The torque speed characteristics of a normal induction motor and an ac servo motor are shown in fig

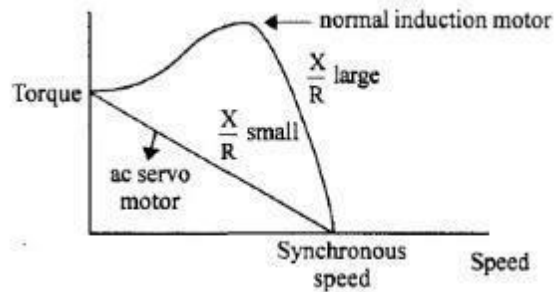

- The Torque speed characteristic of a normal induction motor is highly nonlinear and has a positive slope for some portion of the curve.
- This is not desirable for control applications. as the positive slope makes the systems unstable. The torque speed characteristic of an ac servo motor is fairly linear and has negative slope throughout.
- The rotor construction is usually squirrel cage or drag cup type for an ac servo motor.
- The diameter is small compared to the length of the rotor which reduces inertia of the moving parts.
- Thus it has good accelerating characteristic and good dynamic response.
- The supplies to the two windings of ac servo motor are not balanced as in the case of a normal induction motor.
- The control voltage varies both in magnitude and phase with respect to the constant reference voltage applied to the reference winding.
- The direction of rotation of the motor depends on the phase ($\pm 90^\circ$) of the control voltage with respect to the reference voltage.
- For different rms values of control voltage the torque speed characteristics are shown in Fig.
- The torque varies approximately linearly with respect to speed and also controls voltage.
- The torque speed characteristics can be linearised at the operating point and the transfer function of the motor can be obtained.

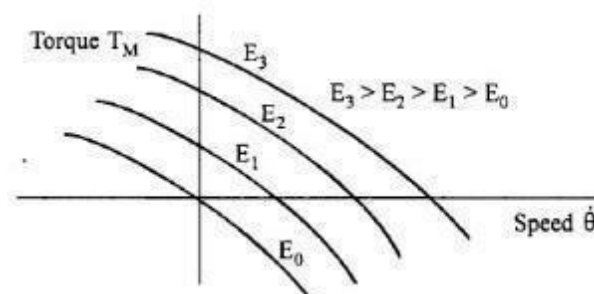

DC Servo Motor

- A DC servo motor is used as an actuator to drive a load. It is usually a DC motor of low power rating.
- DC servo motors have a high ratio of starting torque to inertia and therefore they have a faster dynamic response.

- DC motors are constructed using rare earth permanent magnets which have high residual flux density and high coercivity.
- As no field winding is used, the field copper losses are zero and hence, the overall efficiency of the motor is high.

- The speed torque characteristic of this motor is flat over a wide range, as the armature reaction is negligible.
 - Moreover speed is directly proportional to the armature voltage for a given torque.
 - Armature of a DC servo motor is specially designed to have low inertia.
 - In some applications DC servo motors are used with magnetic flux produced by field windings.
 - The speed of PMDC motors can be controlled by applying variable armature voltage.
 - These are called armature voltage controlled DC servo motors.
 - Wound field DC motors can be controlled by either controlling the armature voltage or controlling the field current. Let us now consider modelling of these two types of DC servo motors.

(a) Armature controlled DC servo motor

The physical model of an armature controlled DC servo motor is given in

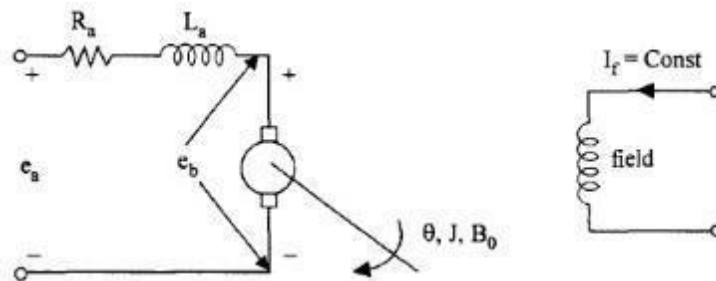

The armature winding has a resistance R_a and inductance L_a .

- The field is produced either by a permanent magnet or the field winding is separately excited and supplied with constant voltage so that the field current I_f is a constant.
- When the armature is supplied with a DC voltage of e_a volts, the armature rotates and produces a back e.m.f e_b .
 - The armature current i_a depends on the difference of e_b and e_a . The armature has a permanent moment of inertia J , frictional coefficient B_0 . The angular displacement of the motor is θ .
 - The torque produced by the motor is given by

$$T = K_T i_a$$

Where K_T is the motor torque constant.

The back emf is proportional to the speed of the motor and hence

$$e_b = K_b \dot{\theta}$$

The differential equation representing the electrical system is given by

$$R_a i_a + L_a \frac{di_a}{dt} + e_b = e_a$$

Taking Laplace transform of equation from above equation

$$T(s) = K_T I_a(s)$$

$$E_b(s) = K_b s \theta(s)$$

$$(R_a + s L_a) I_a(s) + E_b(s) = E_a(s)$$

$$I_a(s) = \frac{E_a(s) - K_b s \theta(s)}{R_a + s L_a}$$

The mathematical model of the mechanical system is given by

$$J \frac{d^2\theta}{dt^2} + B_0 \frac{d\theta}{dt} = T$$

Taking Laplace transform

$$(Js^2 + B_0s) \theta(s) = T(s)$$

Solving for

$$\theta(s) = K_T \frac{E_a(s) - K_b s \theta(s)}{(R_a + s L_a) (Js^2 + B_0s)}$$

$\theta(s)$, we get

The block representation of controlled DC developed in Steps

$$\theta(s) = \frac{K_T E_a(s)}{s[(R_a + s L_a) (Js + B_0) + K_T K_b]}$$

the diagram servo motor is

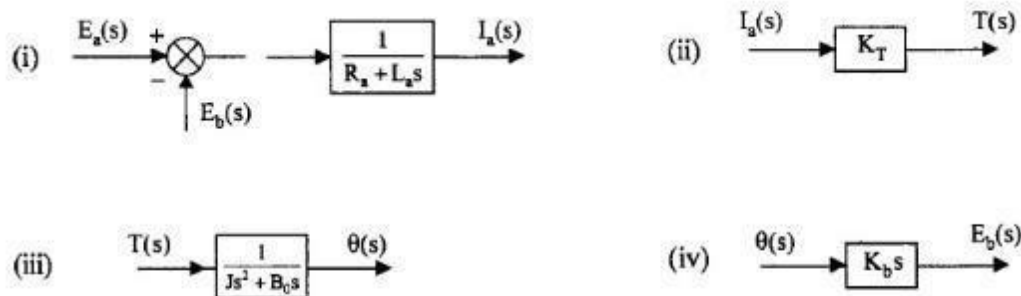

Combining these blocks we have

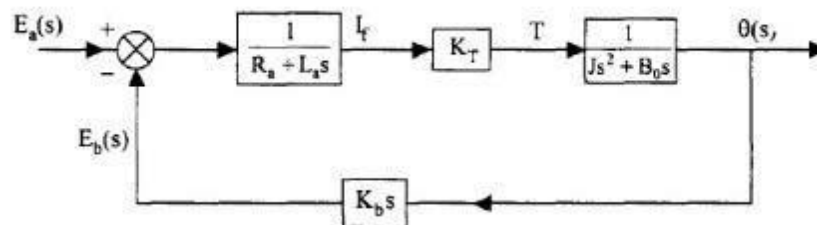

Usually the inductance of the armature winding is small and hence neglected

$$T(s) = \frac{\theta(s)}{E_a(s)} = \frac{K_T/R_a}{s \left[Js + B_0 + \frac{K_b K_T}{R_a} \right]}$$

$$= \frac{K_T/R_a}{s(Js + B)}$$

Where

$$B = B_0 + \frac{K_b K_T}{R_a}$$

Field Controlled Dc Servo Motor The field servo motor

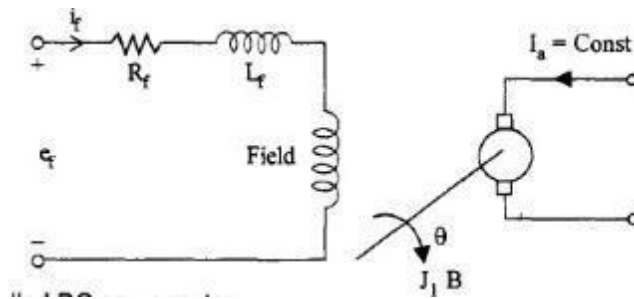

The electrical circuit is modeled as

$$I_f(s) = \frac{E_f(s)}{R_f + L_f s}$$

$$T(s) = K_T I_f(s)$$

$$(Js^2 + B_0) \theta(s) = T(s)$$

$$\begin{aligned} \frac{\theta(s)}{E_f(s)} &= \frac{K_T}{s(Js + B_0)(R_f + L_f s)} \\ &= \frac{K_T / R_f B_0}{s \left(\frac{J}{B_0} s + 1 \right) \left(\frac{L_f}{R_f} s + 1 \right)} \\ &= \frac{K_m}{s(\tau_m s + 1)(\tau_f s + 1)} \end{aligned}$$

Where

Motor gain constant

$$K_m = K_T / R_f B_0$$

Motor time constant

$$\tau_m = J / B_0$$

Field time constant

$$\tau_f = L_f / R_f$$

The block diagram is as shown as

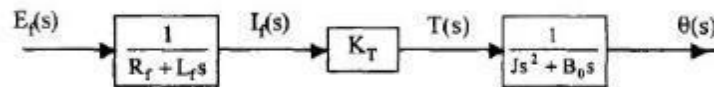

UNIT – II

BLOCK DIAGRAM REDUCTION AND TIME RESPONSE ANALYSIS

Block diagram

A pictorial representation of the functions performed by each component and of the flow of signals.

Basic elements of a block diagram

- Blocks
- Transfer functions of elements inside the blocks
- Summing points
- Take off points
- Arrow

Block diagram

A control system may consist of a number of components. A block diagram of a system is a pictorial representation of the functions performed by each component and of the flow of signals.

The elements of a block diagram are block, branch point and summing point.

Block

In a block diagram all system variables are linked to each other through functional blocks. The functional block or simply block is a symbol for the mathematical operation on the input signal to the block that produces the output.

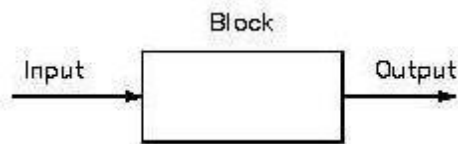

Summing point

Although blocks are used to identify many types of mathematical operations, operations of addition and subtraction are represented by a circle, called a summing point. As shown in Figure a summing point may have one or several inputs. Each input has its own appropriate plus or minus sign.

A summing point has only one output and is equal to the algebraic sum of the inputs.

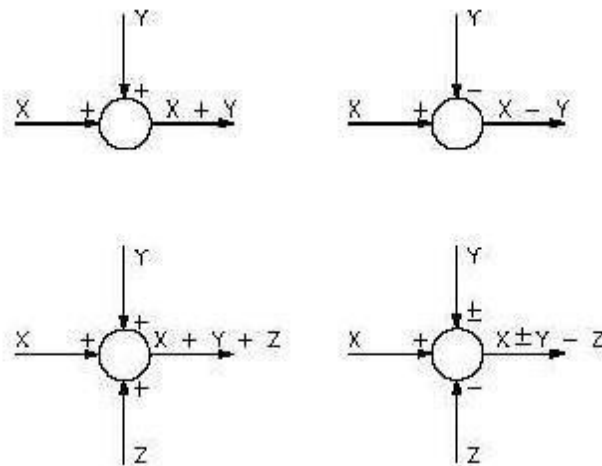

A takeoff point is used to allow a signal to be used by more than one block or summing point. The transfer function is given inside the block

- The input in this case is $E(s)$
- The output in this case is $C(s)$

$$C(s) = G(s) E(s)$$

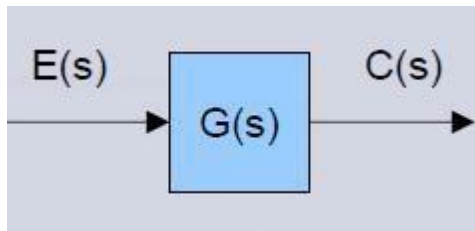

Functional block – each element of the practical system represented by block with its T.F.

Branches – lines showing the connection between the blocks

Arrow – associated with each branch to indicate the direction of flow of signal

Closed loop system

Summing point – comparing the different signals

Take off point – point from which signal is taken for feed back

Advantages of Block Diagram Representation

- Very simple to construct block diagram for a complicated system
- Function of individual element can be visualized
- Individual & Overall performance can be studied Over
- all transfer function can be calculated easily.

Disadvantages of Block Diagram Representation

- No information about the physical construction
- Source of energy is not shown

Simple or Canonical form of closed loop system

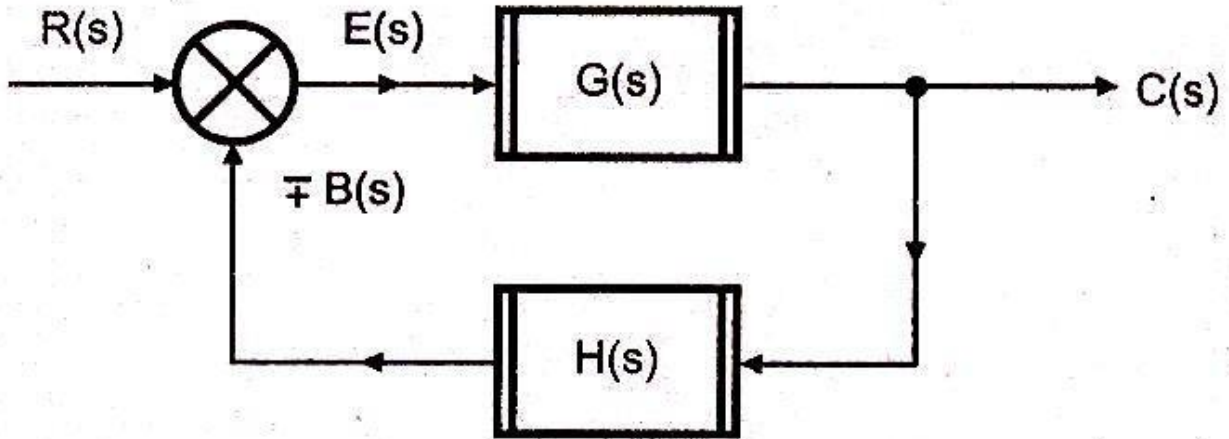

- $R(s)$ – Laplace of reference input $r(t)$
- $C(s)$ – Laplace of controlled output $c(t)$
- $E(s)$ – Laplace of error signal $e(t)$
- $B(s)$ – Laplace of feed back signal $b(t)$
- $G(s)$ – Forward path transfer function
- $H(s)$ – Feed back path transfer function

Block diagram reduction technique

Because of their simplicity and versatility, block diagrams are often used by control engineers to describe all types of systems. A block diagram can be used simply to represent the composition and interconnection of a system. Also, it can be used, together with transfer functions, to represent the cause-and-effect relationships throughout the system. Transfer Function is defined as the relationship between an input signal and an output signal to a device.

Block diagram rules

Cascaded blocks

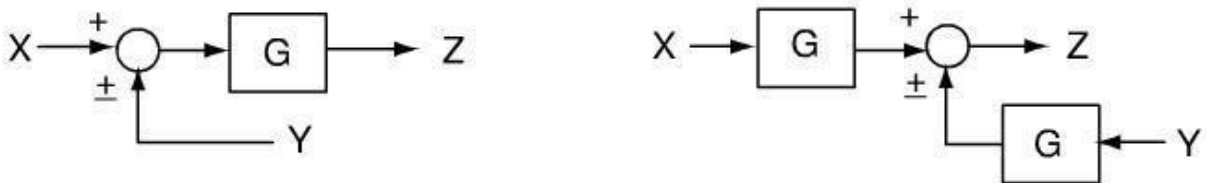

Moving a summer beyond the block

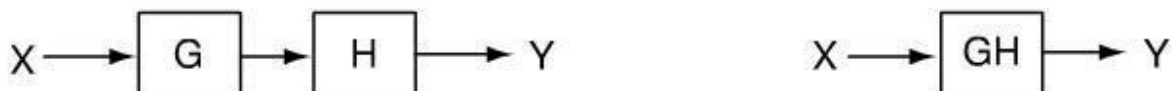

Moving a summer ahead of block

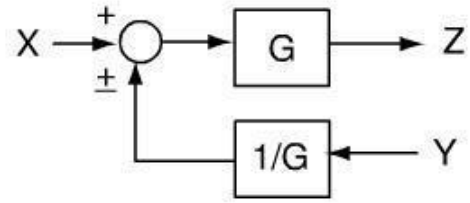
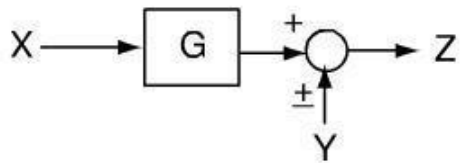

Moving a pick-off ahead of block

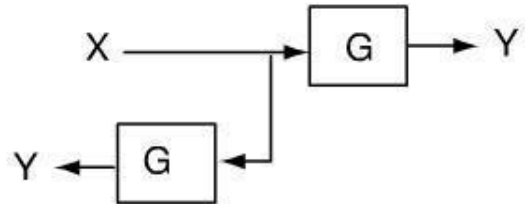
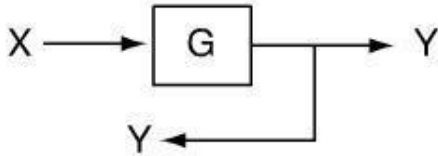

Moving a pick-off behind a block

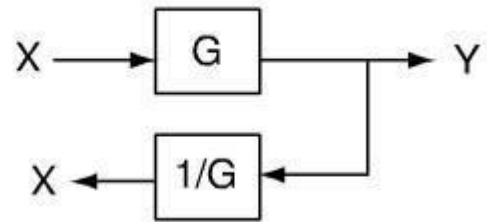
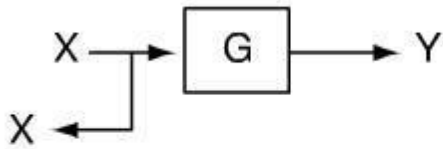

Eliminating a feedback loop

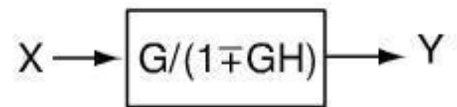
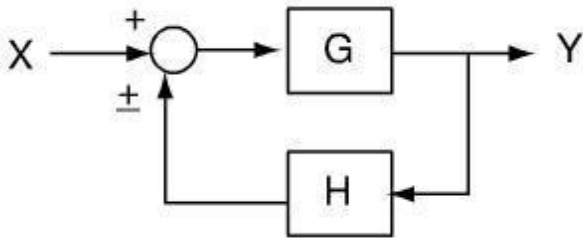

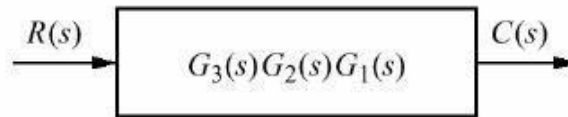
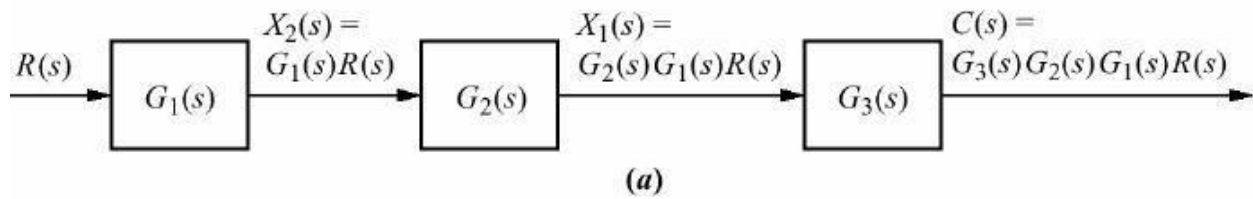

Cascaded Subsystems

Parallel Subsystems

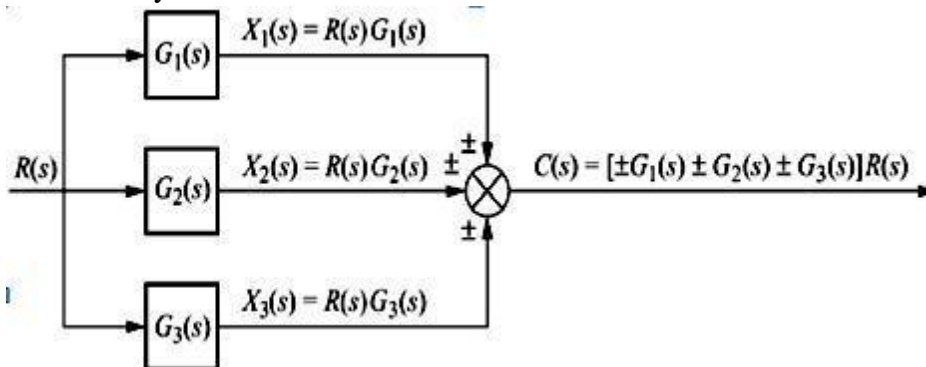

Feedback Control System

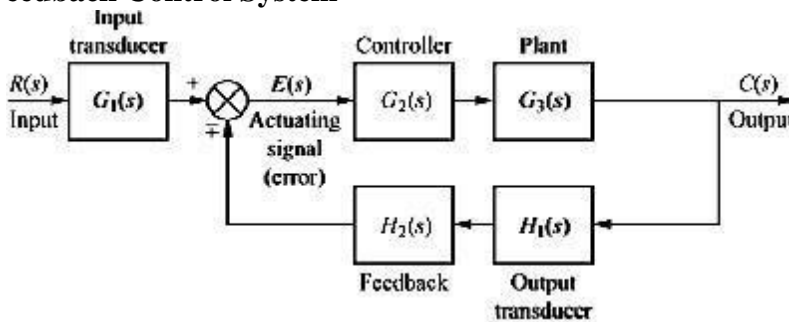

Procedure to solve Block Diagram Reduction

- Problems**
- Step 1: Reduce the blocks connected in series
 - Step 2: Reduce the blocks connected in parallel
 - Step 3: Reduce the minor feedback loops
 - Step 4: Try to shift take off points towards right and Summing point towards left
 - Step 5: Repeat steps 1 to 4 till simple form is obtained
 - Step 6: Obtain the Transfer Function of Overall System

Problem 1

Obtain the Transfer function of the given block diagram

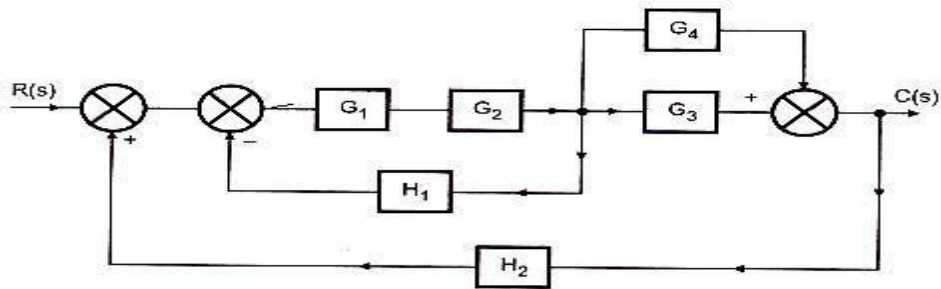

Combine G_1, G_2 which are in series

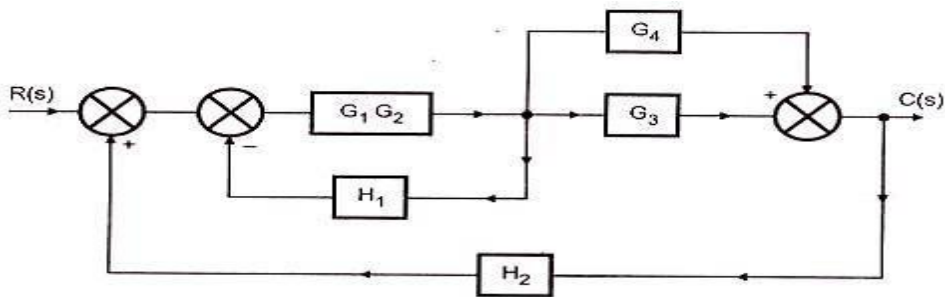

Combine G_3, G_4 which are in Parallel

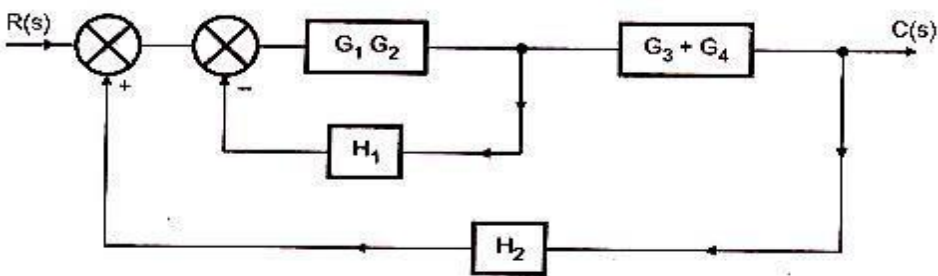

Reduce minor feedback loop of G_1, G_2 and H_1

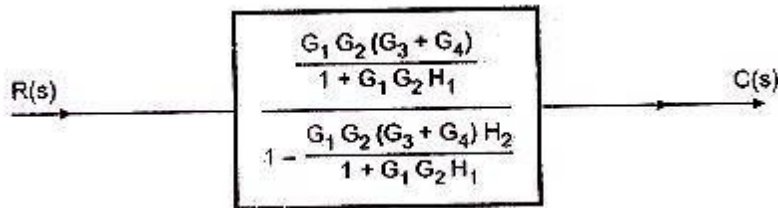
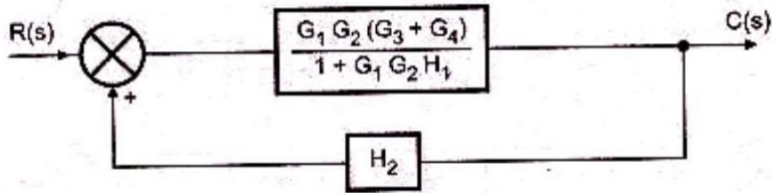
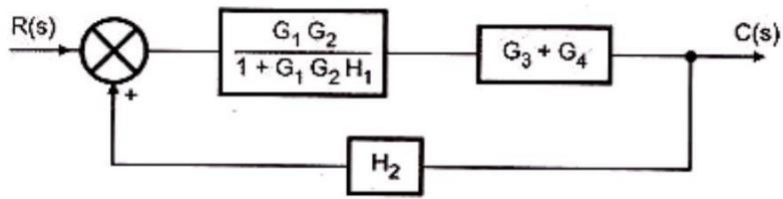

Transfer function

$$\frac{C(s)}{R(s)} = \frac{G_1 G_2 (G_3 + G_4)}{1 + G_1 G_2 H_1 - G_1 G_2 (G_3 + G_4) H_2}$$

2. Obtain the transfer function for the system shown in the fig

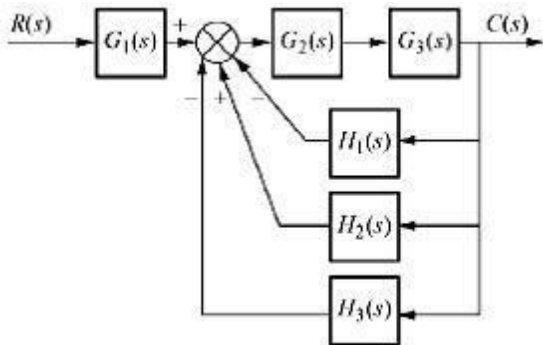

Solution

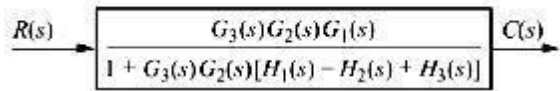
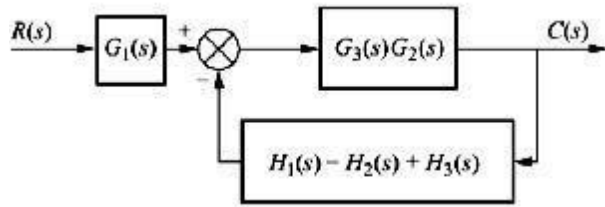

3 . Obtain the transfer function C/R for the block diagram shown in the fig

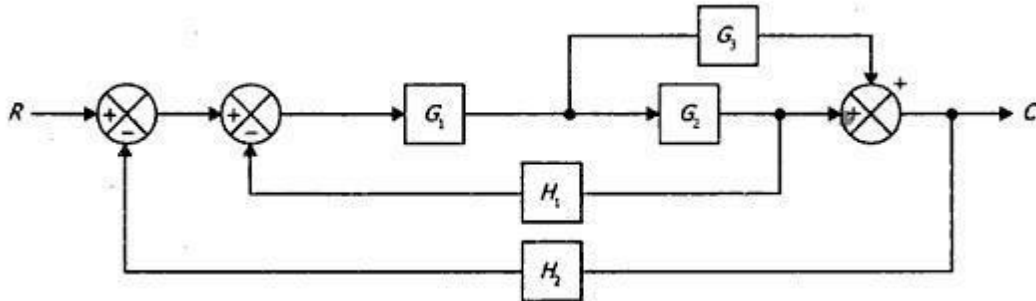

Solution

The take -off point is shifted after the block G2

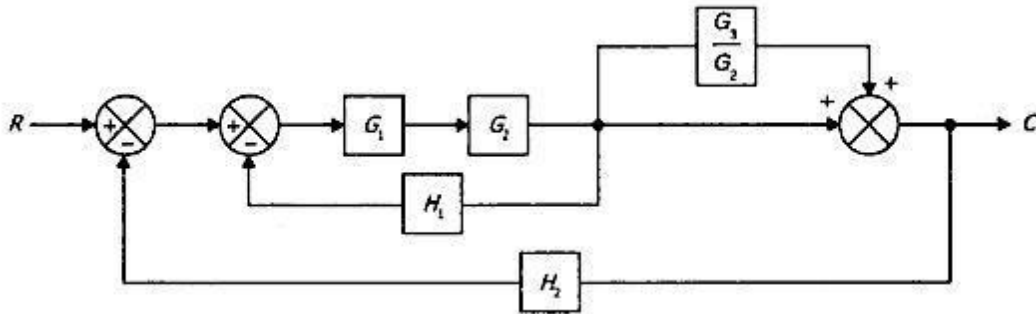

Reducing the cascade block and parallel block

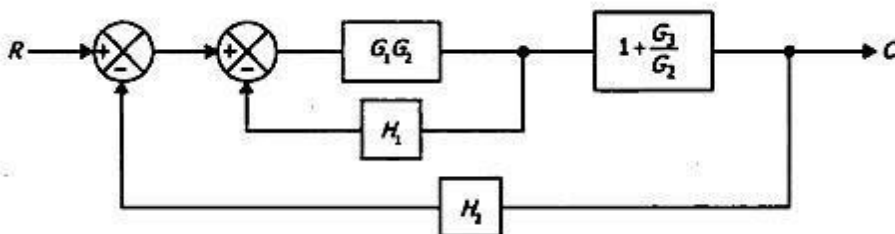

Replacing the internal feedback loop

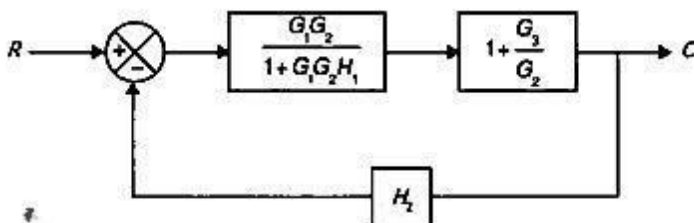

Equivalent block diagram

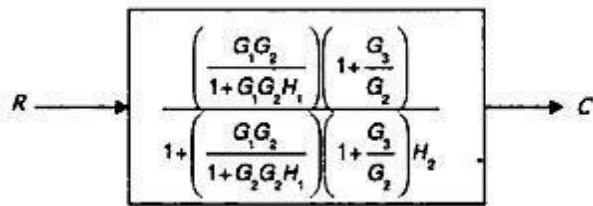

Transfer function

$$\begin{aligned} \frac{C}{R} &= \frac{\frac{G_1 G_2}{1 + G_1 G_2 H_1}}{1 + \frac{G_1 (G_2 + G_3) H_2}{1 + G_1 G_2 H_1}} \\ &= \frac{G_1 (G_2 + G_3)}{1 + G_1 G_2 (H_1 + H_2) + G_1 G_3 H_2} \end{aligned}$$

Signal Flow Graph Representation

Signal Flow Graph Representation of a system obtained from the equations, which shows the flow of the signal

Signal flow graph

A signal flow graph is a diagram that represents a set of simultaneous linear algebraic equations. By taking Laplace transfer, the time domain differential equations governing a control system can be transferred to a set of algebraic equation in s-domain. A signal-flow graph consists of a network in which nodes are connected by directed branches. It depicts the flow of signals from one point of a system to another and gives the relationships among the signals.

Basic Elements of a Signal flow graph

Node - a point representing a signal or variable.

Branch - unidirectional line segment joining two nodes.

Path - a branch or a continuous sequence of branches that can be traversed from one node to another node.

Loop - a closed path that originates and terminates on the same node and along the path no node is met twice.

Nontouching loops - two loops are said to be nontouching if they do not have a common node.

Mason's gain formula

The relationship between an input variable and an output variable of signal flow graph is given by the net gain between the input and the output nodes is known as overall gain of the system. Mason's gain rule for the determination of the overall system gain is given below.

$$M = \frac{1}{\Delta} \sum_{k=1}^N P_k \Delta_k = \frac{X_{out}}{X_{in}}$$

Where M= gain between Xin and Xout

X_{out} = output node variable

X_{in} = input node variable

N = total number of forward paths

P_k = path gain of the k th forward path

$\Delta = 1 - (\text{sum of loop gains of all individual loop}) + (\text{sum of gain product of all possible combinations of two nontouching loops}) - (\text{sum of gain products of all possible combination of three nontouching loops})$

Problem

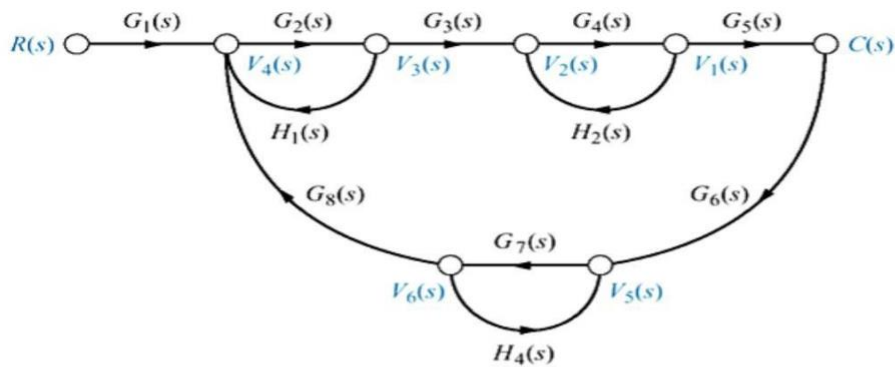

- Forward path gain: $T_1 = G_1(s)G_2(s)G_3(s)G_4(s)G_5(s)$
- Closed loop gain

(1) $G_2(s)H_1(s)$	(2) $G_4(s)H_2(s)$
(3) $G_7(s)H_4(s)$	(4) $G_2(s)G_3(s)G_4(s)G_5(s)G_6(s)G_7(s)G_8(s)$
- Nontouching loops taken two at a time

(5) loop (1) and loop (2): $G_2(s)H_1(s)G_4(s)H_2(s)$
(6) loop (1) and loop (3): $G_2(s)H_1(s)G_7(s)H_4(s)$
(7) loop (2) and loop (3): $G_4(s)H_2(s)G_7(s)H_4(s)$
- Nontouching loops taken three at a time

(8) loops (1), (2), (3): $G_2(s)H_1(s)G_4(s)H_2(s)G_7(s)H_4(s)$

- Now, $\Delta = 1 - \{(1) + (2) + (3) + (4)\} + \{(5) + (6) + (7)\} - (8)$
- Portion of Δ not touching the forward path

$$\Delta_1 = 1 - G_7(s)H_4(s)$$

- Hence,

$$G(s) = \frac{C(s)}{R(s)} = \frac{T_1 \Delta_1}{\Delta}$$

$$= \frac{G_1(s)G_2(s)G_3(s)G_4(s)G_5(s)[1 - G_7(s)H_4(s)]}{\Delta}$$

TIME RESPONSE

Introduction

- After deriving a mathematical model of a system, the system performance analysis can be done in various methods.

- In analyzing and designing control systems, a basis of comparison of performance of various control systems should be made. This basis may be set up by specifying particular test input signals and by comparing the responses of various systems to these signals.
- The system stability, system accuracy and complete evaluation are always based on the time response analysis and the corresponding results.
- Next important step after a mathematical model of a system is obtained.
- To analyze the system's performance.
- Normally use the standard input signals to identify the characteristics of system's response
 - Step function
 - Ramp function
 - Impulse function
 - Parabolic function
 - Sinusoidal function

2.10 Time response analysis

It is an equation or a plot that describes the behavior of a system and contains much information about it with respect to time response specification as overshooting, settling time, peak time, rise time and steady state error. Time response is formed by the transient response and the steady state response.

$$\text{Time response} = \text{Transient response} + \text{Steady state response}$$

Transient time response (Natural response) describes the behavior of the system in its first short time until arrives the steady state value and this response will be our study focus. If the input is step function then the output or the response is called step time response and if the input is ramp, the response is called ramp time response ... etc.

Classification of Time Response

- Transient response
 - Steady state response
- $$y(t) = y_t(t) + y_{ss}(t)$$

Transient Response

The transient response is defined as the part of the time response that goes to zero as time becomes very large. Thus $y_t(t)$ has the property

$$\lim_{t \rightarrow \infty} y_t(t) = 0$$

The time required to achieve the final value is called transient period. The transient response may be exponential or oscillatory in nature. Output response consists of the sum of forced response (from the input) and natural response (from the nature of the system). The transient response is the change in output response from the beginning of the response to the

final state of the response and the steady state response is the output response as time is approaching infinity (or no more changes at the output).

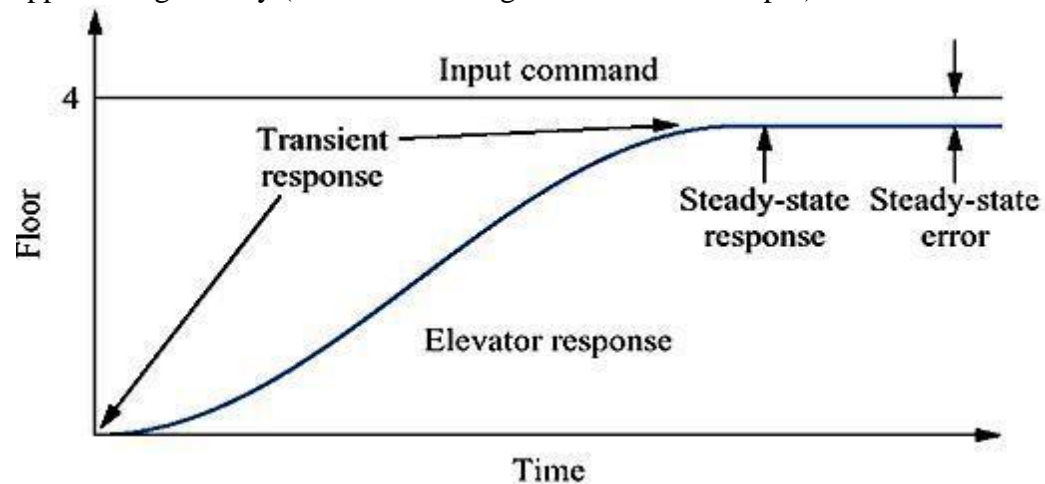

Steady State Response

The steady state response is the part of the total response that remains after the transient has died out. For a position control system, the steady state response when compared to with the desired reference position gives an indication of the final accuracy of the system. If the steady state response of the output does not agree with the desired reference exactly, the system is said to have steady state error.

2.3 Typical Input Signals

- Impulse Signal
- Step Signal
- Ramp Signal
- Parabolic Signal

Input	Function	Description	Sketch	Use
Impulse	$\delta(t)$	$\delta(t) = \infty$ for $0^- < t < 0^+$ $= 0$ elsewhere $\int_{0^-}^{0^+} \delta(t) dt = 1$		Transient response Modeling
Step	$u(t)$	$u(t) = 1$ for $t > 0$ $= 0$ for $t < 0$		Transient response Steady-state error
Ramp	$tu(t)$	$tu(t) = t$ for $t \geq 0$ $= 0$ elsewhere		Steady-state error
Parabola	$\frac{1}{2}t^2u(t)$	$\frac{1}{2}t^2u(t) = \frac{1}{2}t^2$ for $t \geq 0$ $= 0$ elsewhere		Steady-state error
Sinusoid	$\sin \omega t$			Transient response Modeling Steady-state error

Time Response Analysis & Design

Two types of inputs can be applied to a control system.

Command Input or Reference Input $y_r(t)$.

Disturbance Input $w(t)$ (External disturbances $w(t)$ are typically uncontrolled variations in the load on a control system).

In systems controlling mechanical motions, load disturbances may represent forces.

In voltage regulating systems, variations in electrical load area major source of disturbances.

Test Signals

Input	$r(t)$	$R(s)$
Step Input	A	A/s
Ramp Input	At	$\frac{A}{s^2}$
Parabolic Input	$At^2 / 2$	$\frac{A}{s^3}$

Impulse Input	$\delta(t)$	1
---------------	-------------	---

Transfer Function

- One of the types of Modeling a system
- Using first principle, differential equation is obtained
- Laplace Transform is applied to the equation assuming zero initial conditions
- Ratio of LT (output) to LT (input) is expressed as a ratio of polynomial in s in the transfer function.

Order of a system

- The Order of a system is given by the order of the differential equation governing the system
- Alternatively, order can be obtained from the transfer function
- In the transfer function, the maximum power of s in the denominator polynomial gives the order of the system.

Dynamic Order of Systems

- Order of the system is the order of the differential equation that governs the dynamic behaviour
- Working interpretation: Number of the dynamic elements / capacitances or holdup elements between a
 - manipulated variable and a controlled variable
- Higher order system responses are usually very difficult to resolve from one another
- The response generally becomes sluggish as the order increases.

System Response

First-order system time response

- ❖ Transient
- ❖ Steady-state



Transient

- ❖ Steady-state

First Order System

$$Y(s) / R(s) = K / (1 + KsT) = K / (1 + sT)$$

Step Response of First Order System

Evolution of the transient response is determined by the pole of the transfer function at $s = -1/t$ where t is the time constant Also, the step response can be found:

Impulse response	$K / (1 + sT)$	Exponential
Step response	$(K/S) - (K / (S + (1/T)))$	Step, exponential
Ramp response	2	Ramp, step, exponential

	$(K/S) - (KT/S) - (KT/(S+1/T))$	
--	---------------------------------	--

Second-order systems

LTI second -order system

$$G(s) = \frac{C(s)}{R(s)} = \frac{\omega_n^2}{s^2 + 2\zeta\omega_n s + \omega_n^2}$$

$$(s^2 + 2\zeta\omega_n s + \omega_n^2) C(s) = \omega_n^2 R(s)$$

$$c(t) + 2\zeta\omega_n c(t) + \omega_n^2 c(t) = \omega_n^2 r(t)$$

Second -Order Systems

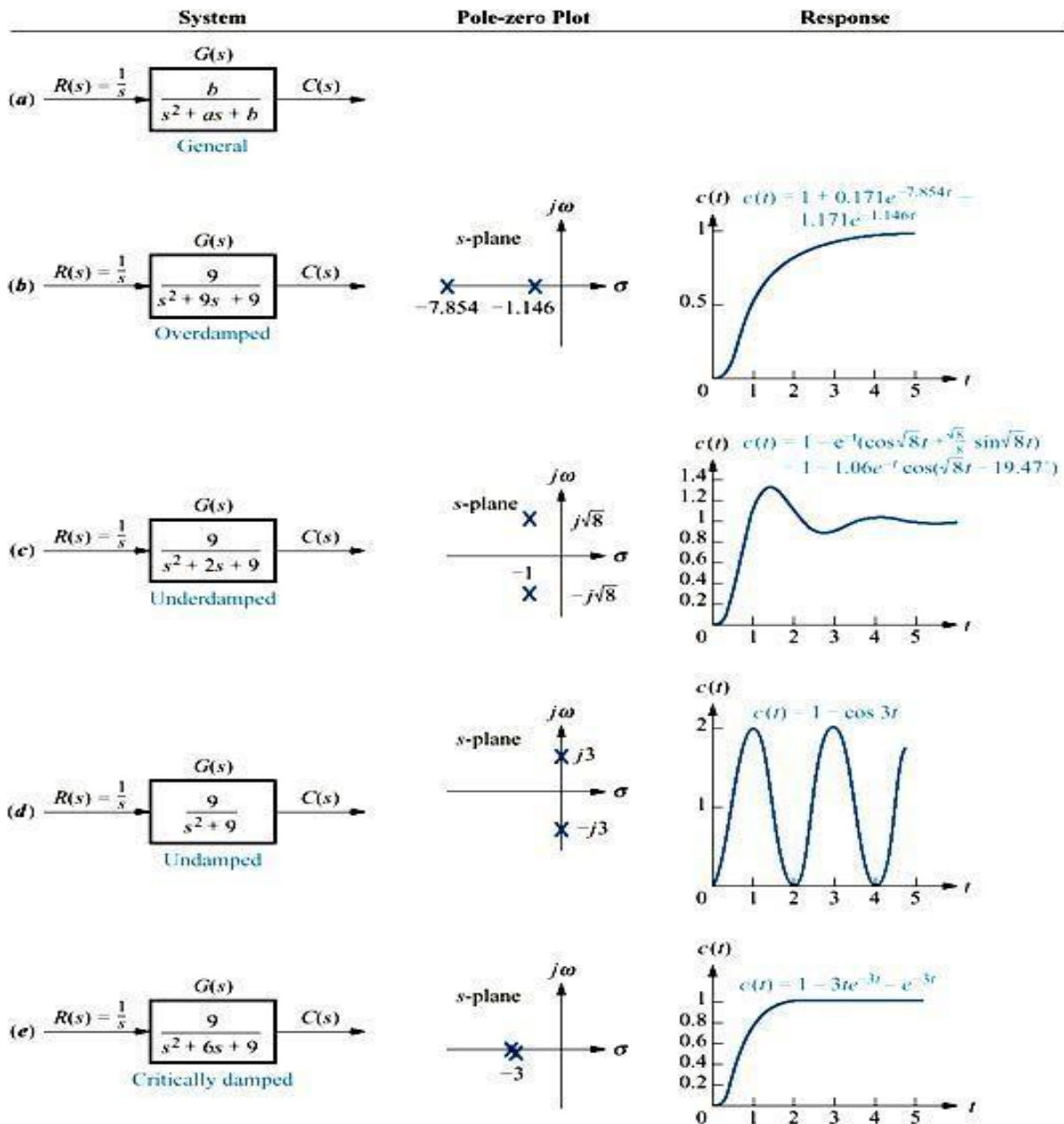

Second order system responses

Overdamped response:

Poles: Two real at

$$-\zeta_1 - \zeta_2$$

Natural response: Two exponentials with time constants equal to the reciprocal of the pole location

$$C(t) = k_1 e^{-\zeta_1 t} + k_2 e^{-\zeta_2 t}$$

Poles: Two complex at

Underdamped response:

$$-\zeta \pm j\omega_d$$

Natural response: Damped sinusoid with an exponential envelope whose time constant is equal to the reciprocal of the pole's radian frequency of the sinusoid, the damped frequency of oscillation, is equal to the imaginary part of the poles

Undamped Response:

Poles: Two imaginary at

$$\pm j\omega_1$$

Natural response: Undamped sinusoid with radian frequency equal to the imaginary part of the poles

$$C(t) = A \cos(\omega_1 t - \phi)$$

Critically damped responses:

Poles: Two real at

Natural response: One term is an exponential whose time constant is equal to the reciprocal of the pole location. Another term product of time and an exponential with time constant equal to the reciprocal of the pole location.

Second order system responses damping cases

**Second-order step
Complex poles**

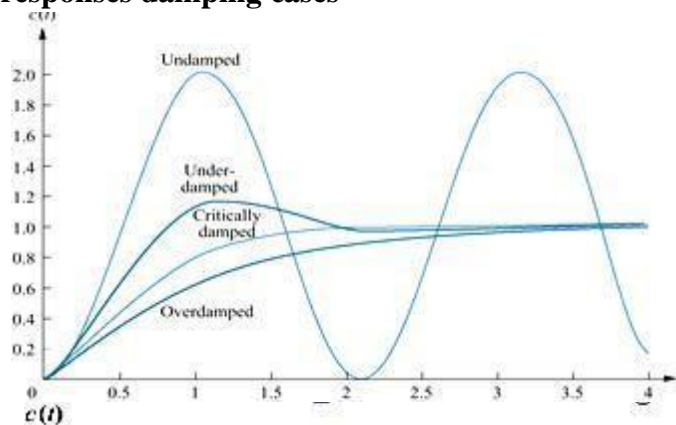

response

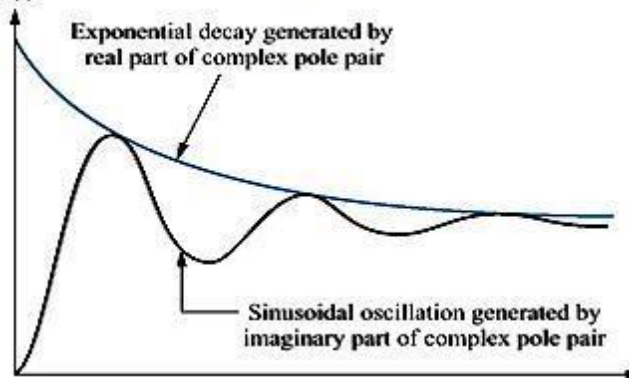

Steady State Error

Consider a unity feedback system

Transfer function between $e(t)$ and $r(t)$

Output Feedback

Type of system	Error constants			Steady state error e_{ss}		
	K_p	K_v	K_a	Unit step input	Unit ramp input	Unit parabolic input
0	K	0	0	$1/(1+K)$	∞	∞
1	∞	K	0	0	$1/K$	∞
2	∞	∞	K	0	0	$1/K$
3	∞	∞	∞	0	0	0

Control Systems

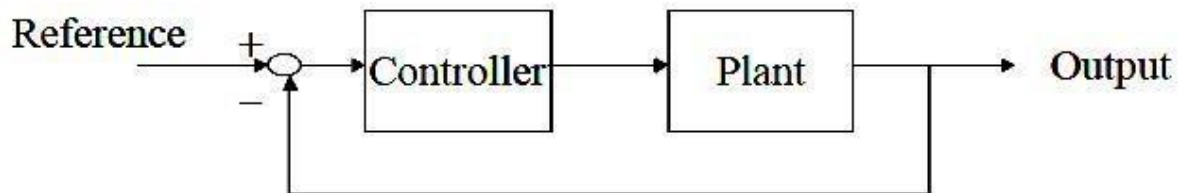

Feedback only the output signal

- Easy access
- Obtainable in practice

PID Controllers

Proportional controllers

- pure gain or attenuation

Integral controllers

- integrate error

Derivative controllers

- differentiate error

Proportional Controller

$$U = K_p e$$

- Controller input is error (reference output)
- Controller output is control signal
- P controller involves only a proportional gain (or attenuation)

Integral Controller

- Integral of error with a constant gain
- Increase system type by 1
- Infinity steady-state gain
- Eliminate steady-state error for a unit step input

Integral Controller

$$\frac{Y(s)}{R(s)} = \frac{G_p(s)}{1 + G_p(s)}$$

$$Y(s) = E(s)G_p(s)$$

$$E(s) = \frac{R(s)}{1 + G_p(s)}$$

$$e_{ss} = \lim_{t \rightarrow \infty} e(t) = \lim_{s \rightarrow 0} sE(s) = \lim_{s \rightarrow 0} \frac{sR(s)}{1 + G_p(s)} = \lim_{s \rightarrow 0} \frac{1}{1 + G_p(s)} = \frac{1}{1 + \infty} = 0$$

Derivative Control

- Differentiation of error with $u = K_d \frac{de}{dt}$ a constant gain
- Reduce overshoot and oscillation
- Do not affect steady-state
- response Sensitive to noise

Controller Structure

- Single controller
- P controller, I controller, D controller
- Combination of controllers
- PI controller, PD controller
- PID controller

Controller

- **Performance**
- P controller
- PI controller PD
- Controller PID
- Controller

Design of PID Controllers

- Based on the knowledge of P, I and D
- – trial and error
- – manual tuning
- – simulation

Design of PID Controllers

- Time response measurements are particularly simple.
- A step input to a system is simply a suddenly applied input - often just a constant voltage applied through a switch.
- The system output is usually a voltage, or a voltage output from a transducer measuring the output.
- A voltage output can usually be captured in a file using a C program or a Visual Basic program.
- You can use responses in the time domain to help you determine the transfer function of a system.
- First we will examine a simple situation. Here is the step response of a system. This is an example of really "clean" data, better than you might have from measurements. The input to the system is a step of height 0.4. The goal is to determine the transfer function of the system.

Impulse Response of A First Order System

- The impulse response of a system is an important response. The impulse response is the response to a unit impulse.
- The unit impulse has a Laplace transform of unity (1). That gives the unit impulse a unique stature. If a system has a unit impulse input, the output transform is $G(s)$, where $G(s)$ is the transfer function of the system. The unit impulse response is therefore the inverse transform of $G(s)$, i.e. $g(t)$, the time function you get by inverse transforming $G(s)$. If you haven't begun to study Laplace transforms yet, you can just file these last statements away until you begin to learn about Laplace transforms. Still there is an important fact buried in all of this.

• Knowing that the impulse response is the inverse transform of the transfer function of a system can be useful in identifying systems (getting system parameters from measured responses).

In this section we will examine the shapes/forms of several impulse responses. We will start with simple first order systems, and give you links to modules that discuss other, higher order responses.

A general first order system satisfies a differential equation with this general form

If the input, $u(t)$, is a unit impulse, then for a short instant around $t = 0$ the input is infinite. Let us assume that the state, $x(t)$, is initially zero, i.e. $x(0) = 0$. We will integrate both sides of the differential equation from a small time, ϵ , before $t = 0$, to a small time, ϵ , after $t = 0$. We are just taking advantage of one of the properties of the unit impulse.

The right hand side of the equation is just Gdc since the impulse is assumed to be a unit impulse - one with unit area. Thus, we have:

We can also note that $x(0) = 0$, so the second integral on the right hand side is zero. In other words, what the impulse does is it produces a calculable change in the state, $x(t)$, and this change occurs in a negligibly short time (the duration of the impulse) after $t = 0$. That leads us to a simple strategy for getting the impulse response. Calculate the new initial condition after the impulse passes. Solve the differential equation - with zero input - starting from the newly calculated initial condition.

Time Domain Specifications of a Second Order System

The performance of a system is usually evaluated in terms of the following qualities. .

- How fast it is able to respond to the input.
- How fast it is reaching the desired output
- What is the error between the desired output and the actual output, once the transients die down and steady state is achieved
- Does it oscillate around the desired value, and
- Is the output continuously increasing with time or is it bounded.
- The last aspect is concerned with the stability of the system and we would require the system to be stable. This aspect will be considered later. The first four questions will be answered in terms of time domain specifications of the system based on its response to a unit step input.
- These are the specifications to be given for the design of a controller for a given system.
- We have obtained the response of a type 1 second order system to a unit step input. The step response of a typical underdamped second order system is plotted in Fig.

It is observed that for an underdamped system, there are two complex conjugate poles. Usually, the two complex poles nearest to the j -axis (called dominant poles) are considered, and the system is approximated by a second order system. Thus, in designing any system, certain design specifications are given based on the typical underdamped step response shown as Fig.

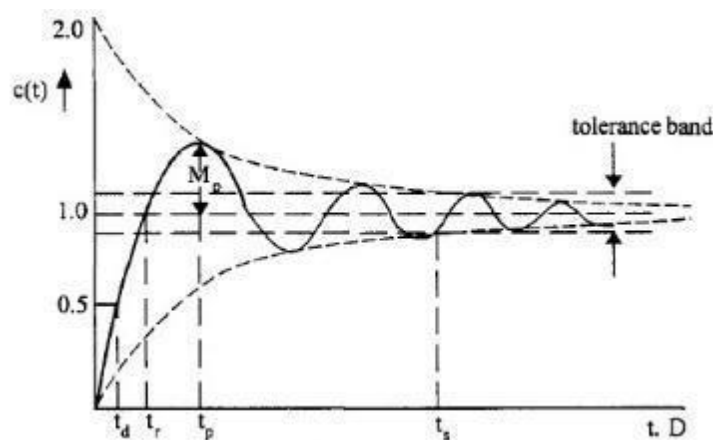

that, for an underdamped system, there are two complex conjugate poles. Usually, the two complex poles nearest to the j -axis (called dominant poles) are considered, and the system is approximated by a second order system. Thus, in designing any system,

The design specifications are

Delay time t_d : It is the time required for the response to reach 50% of the steady state value for the first time.

Rise time t_r : It is the time required for the response to reach 100% of the steady state value for under damped systems. However, for over damped systems, it is taken as the time required for the response to rise from 10% to 90% of the steady state value.

Peak time t_p : It is the time required for the response to reach the maximum or Peak value of the response.

Peak overshoot M_p : It is defined as the difference between the peak value of the response and the steady state value. It is usually expressed in percent of the steady state value. If the time for the peak is t_p , percent peak overshoot is given by,

$$M_p = \frac{c(t_p) - c(\infty)}{c(\infty)} \times 100.$$

Root Locus Technique

- Introduced by W. R. Evans in 1948
- Graphical method, in which movement of poles in the s-plane is sketched when some parameter is varied. The path taken by the roots of the characteristic equation when open loop gain K is varied from 0 to ∞ are called root loci
- Direct Root Locus = $0 < k < \infty$
- Inverse Root Locus = $-\infty < k < 0$

Root Locus Analysis:

- The roots of the closed-loop characteristic equation define the system characteristic responses
- Their location in the complex s-plane lead to prediction of the characteristics of the time domain responses in terms of:
 - damping ratio ζ , natural
 - frequency, ω_n
 - damping constant ζ ,
 - first-order modes

Consider how these roots change as the loop gain is varied from 0 to ∞

Basics of Root Locus:

- Symmetrical about real axis
- RL branch starts from OL poles and terminates at OL zeroes
- No. of RL branches = No. of poles of OLTF
- Centroid is common intersection point of all the asymptotes on the real axis
- Asymptotes are straight lines which are parallel to RL going to ∞ and meet the RL at ∞
- No. of asymptotes = No. of branches going to ∞
- At Break Away point, the RL breaks from real axis to enter into the complex plane
- At Break In point, the RL enters the real axis from the complex plane

Constructing Root Locus:

- Locate the OL poles & zeros in the plot
- Find the branches on the real axis
- Find angle of asymptotes &
- centroid $\Phi_a = \pm 180^\circ(2q+1) / (n-m)$
- $\zeta_a = (\Sigma \text{poles} - \Sigma \text{zeros}) / (n-m)$
- Find BA and BI points
- Find Angle Of departure (AOD) and Angle Of Arrival (AOA)

AOD = $180^\circ - (\text{sum of angles of vectors to the complex pole from all other poles}) + (\text{Sum of angles of vectors to the complex pole from all zero})$

- AOA = $180^\circ - (\text{sum of angles of vectors to the complex zero from all other zeros}) + (\text{sum of angles of vectors to the complex zero from poles})$
- Find the point of intersection of RL with the imaginary axis.

Application of the Root Locus Procedure

Step 1: Write the characteristic equation as

$$1 + F(s) = 0$$

Step 2: Rewrite preceding equation into the form of poles and zeros as follows

$$1 + K \frac{\prod_{j=1}^m (s - z_j)}{\prod_{i=1}^n (s - p_i)} = 0$$

Step 3:

- Locate the poles and zeros with specific symbols, the root locus begins at the open-loop poles and ends at the open loop zeros as K increases from 0 to infinity
- If open-loop system has n-m zeros at infinity, there will be n-m branches of the root locus approaching the n-m zeros at infinity

Step 4:

- The root locus on the real axis lies in a section of the real axis to the left of an odd number of real poles and zeros

Step 5:

- The number of separate loci is equal to the number of open-loop poles

Step 6:

- The root loci must be continuous and symmetrical with respect to the horizontal real axis

Step 7:

- The loci proceed to zeros at infinity along asymptotes centered at centroid and with angles

$$\sigma_a = \frac{\sum_{i=1}^n p_i - \sum_{j=1}^m z_j}{n-m}$$

$$\phi_a = \frac{(2k+1)\pi}{n-m} \quad (k = 0, 1, 2, \dots, n-m-1)$$

Step 8:

- The actual point at which the root locus crosses the imaginary axis is readily evaluated by using Routh's criterion

Step 9:

Determine the breakaway point d (usually on the real axis) Step

10:

- Plot the root locus that satisfy the phase criterion

$$\angle P(s) = (2k+1)\pi \quad k = 1, 2, \dots$$

Step 11:

Determine the parameter value K_1 at a specific root using the magnitude criterion

$$K_1 = \frac{\prod_{i=1}^n |(s - p_i)|}{\prod_{j=1}^m |(s - z_j)|} \Bigg|_{s=s_1}$$

**UNIT 3 CONCEPT
ROOT LOCUS**

**OF STABILITY AND
TECHNIQUE**

Frequency Response

The frequency response of a system is a frequency dependent function which expresses how a sinusoidal signal of a given frequency on the system input is transferred through the system. Time-varying signals at least periodical signals—which excite systems, as the reference (set point) signal or a disturbance in a control system or measurement signals which are inputs signals to signal filters, can be regarded as consisting of a sum of frequency components. Each frequency component is a sinusoidal signal having certain amplitude and a certain frequency. (The Fourier series expansion or the Fourier transform can be used to express these frequency components quantitatively.) The frequency response expresses how each of these frequency components is transferred through the system. Some components may be amplified, others may be attenuated, and there will be some phase lag through the system.

The frequency response is an important tool for analysis and design of signal filters (as low pass filters and high pass filters), and for analysis, and to some extent, design, of control systems. Both signal filtering and control systems applications are described (briefly) later in this UNIT. The definition of the frequency response—which will be given in the next section—applies only to linear models, but this linear model may very well be the local linear model about some operating point of a non-linear model. The frequency response can be found experimentally or from a transfer function model. It can be presented graphically or as a mathematical function.

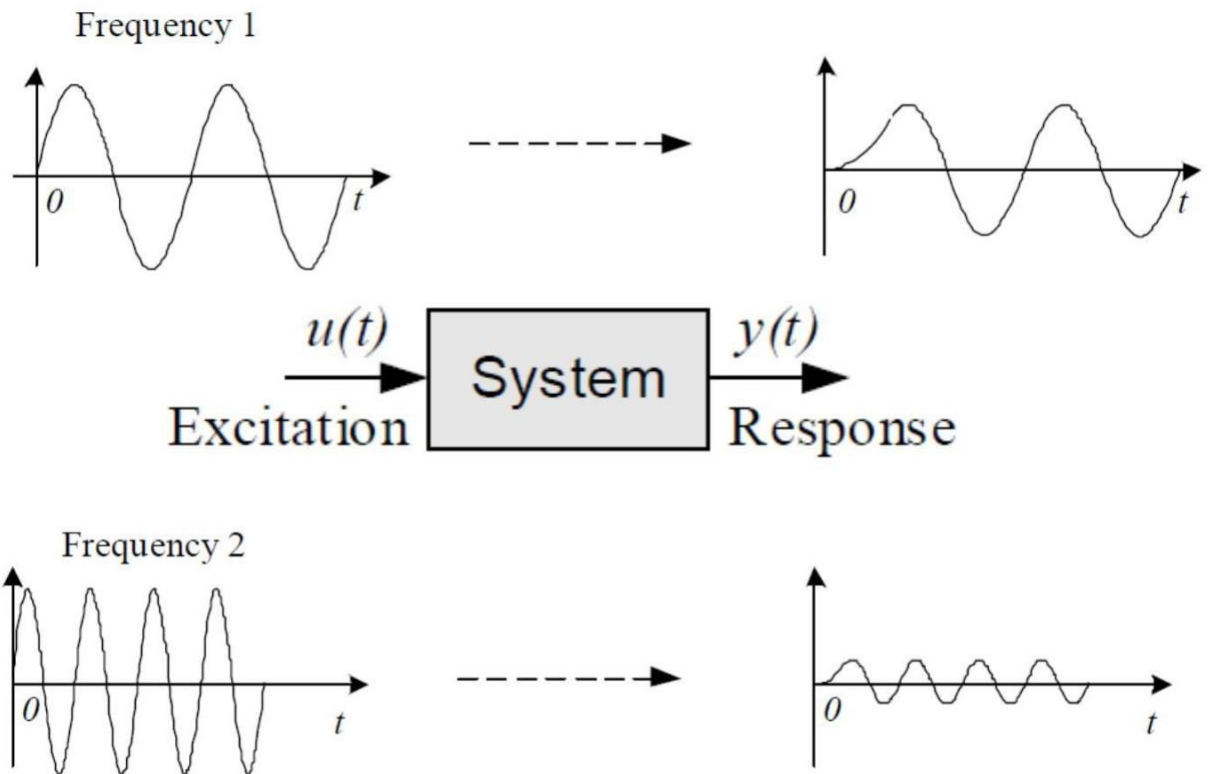

Bode plot

- Plots of the magnitude and phase characteristics are used to fully describe the frequency response
- A **Bode plot** is a (semilog) plot of the transfer function magnitude and phase angle as a function of frequency.

The gain magnitude is many times expressed in terms of decibels (dB) db
 $= 20 \log_{10} A$

BODE PLOT PROCEDURE:

There are 4 basic forms in an open-loop transfer function $G(j\omega)H(j\omega)$

- Gain Factor K
- $(j\omega)^{\pm p}$ factor: pole and zero at origin
- $(1+j\omega T)^{\pm q}$ factor
- Quadratic factor

$$1 + j2\zeta(W / W_n) - (W / W_n)^2$$

Gain margin and Phase margin

Gain margin:

The gain margin is the number of dB that is below 0 dB at the phase crossover frequency ($\phi = -180^\circ$). It can also be increased before the closed loop system becomes unstable

Term	Corner Frequency	Slope db /dec	Change in slope
------	------------------	---------------	-----------------

$20/j\omega$	-----	-20	
$1/(1+4j\omega)$	$WC_1=1/4 = 0.25$	-20	$-20-20=-40$
$1/(1+j3\omega)$	$wc_2=1/3=0.33$	-20	$-40-20=-60$

Phase margin:

The phase margin is the number of degrees the phase of that is above -180° at the gain crossover frequency

Gain margin and Phase margin

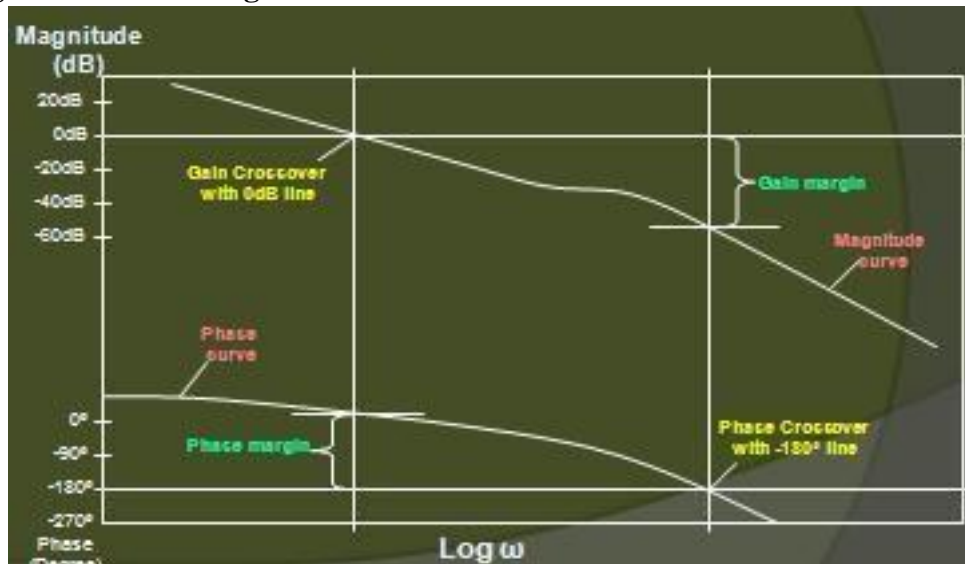

Bode Plot – Example

For the following T.F draw the Bode plot and obtain Gain cross over frequency (w_{gc}), Phase cross over frequency, Gain Margin and Phase Margin. $G(s) = 20 / [s(1+3s)(1+4s)]$

Solution:

The sinusoidal T.F of $G(s)$ is obtained by replacing s by $j\omega$ in the given T.F

$$G(j\omega) = 20 / [j\omega(1+j3\omega)(1+j4\omega)]$$

Corner frequencies:

$$w_{c1} = 1/4 = 0.25 \text{ rad/sec ;}$$

$$w_{c2} = 1/3 = 0.33 \text{ rad/sec}$$

Choose a lower corner frequency and a higher Corner frequency $w_l = 0.025 \text{ rad/sec ;}$

$$w_h = 3.3 \text{ rad/sec}$$

Calculation of Gain (A) (MAGNITUDE PLOT)

$$A @ w_l ; A = 20 \log [20 / 0.025] = 58.06 \text{ dB}$$

$$A @ w_{c1} ; A = [\text{Slope from } w_l \text{ to } w_{c1} \times \log (w_{c1} / w_l)] + \text{Gain (A)} @ w_l$$

$$= -20 \log [0.25 / 0.025] + 58.06$$

$$= 38.06 \text{ dB}$$

$$A @ \omega c2 ; A = [\text{Slope from } \omega c1 \text{ to } \omega c2 \times \log (\omega c2 / \omega c1) + \text{Gain (A)@ } \omega c1 =$$

$$-40 \log [0.33 / 0.25] + 38$$

$$= 33 \text{ dB}$$

$$A @ \omega h ; A = [\text{Slope from } \omega c2 \text{ to } \omega h \times \log (\omega h / \omega c2) + \text{Gain (A) @ } \omega c2$$

$$= -60 \log [3.3 / 0.33] +$$

$$33 = -27 \text{ dB}$$

Calculation of Phase angle for different values of frequencies [PHASE PLOT] ω^{-1} ω^{-1}

$$\phi = -90 - \tan^{-1} 3\omega - \tan^{-1} \frac{1}{4\omega}$$

When

Frequency in rad / sec	Phase angles in Degree
$\omega=0$	0° $\phi = -90^\circ$
$\omega = 0.025$	$\phi = -99^\circ$
$\omega = 0.25$	$\phi = -172^\circ$
$\omega = 0.33$	0° $\phi = -188^\circ$
$\omega = 3.3$	$\phi = -259^\circ$
$\omega = \infty$	$\phi = -270^\circ$

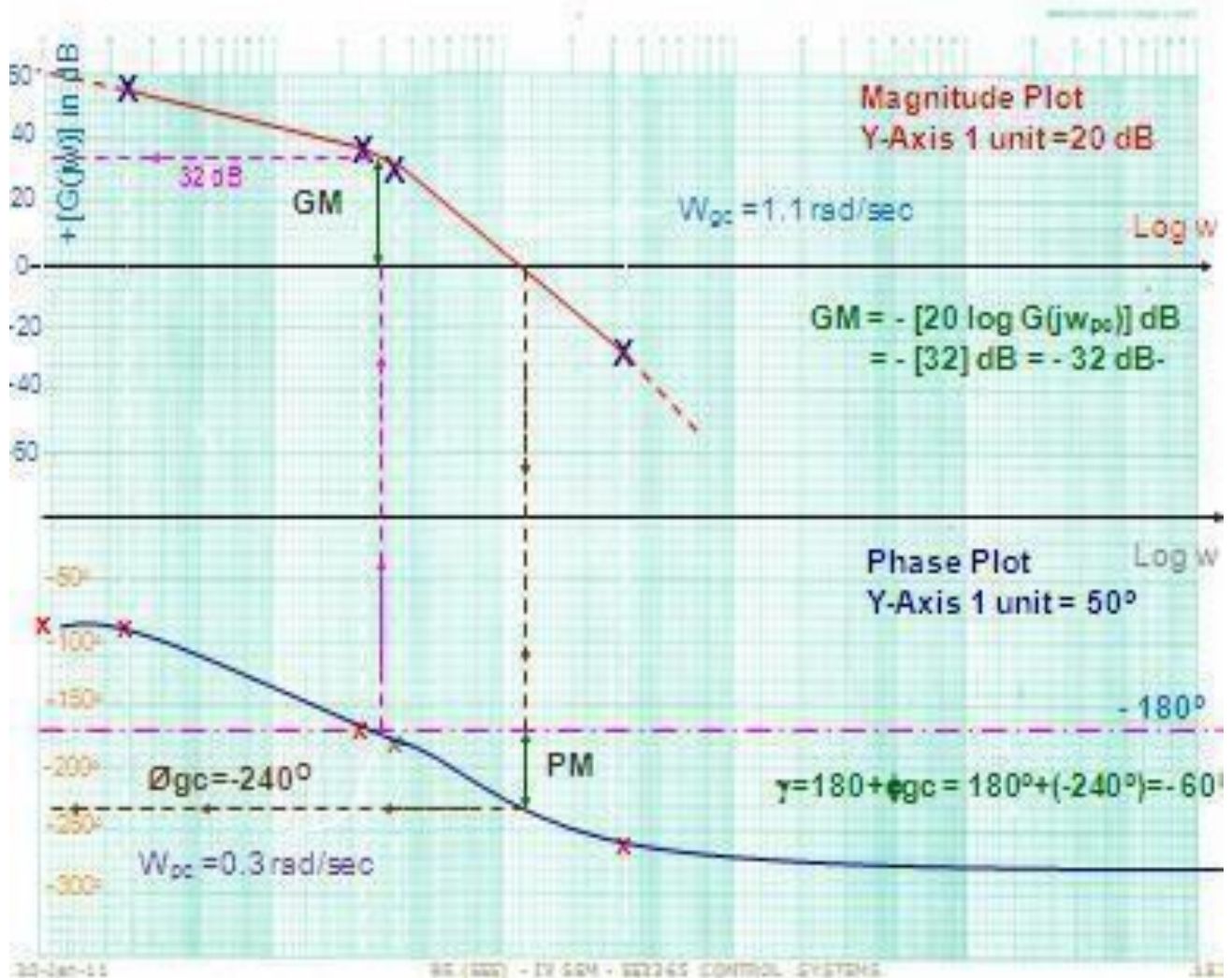

- **Calculations of Gain cross over frequency**

The frequency at which the dB magnitude is Zero wgc
 $= 1.1 \text{ rad / sec}$

- **Calculations of Phase cross over frequency** The frequency at which the Phase of the system is $- 180^\circ$ wpc
 $= 0.3 \text{ rad / sec}$

- **Gain Margin**

The gain margin in dB is given by the negative of dB magnitude of $G(j\omega)$ at phase cross over frequency

$$\text{GM} = - \{ 20 \log [G(j\omega_{pc})] \} = - \{ 32 \} = -32 \text{ dB}$$

- **Phase Margin**

$$\gamma = 180 + \phi_{gc} = 180 + (- 240^\circ) = -60^\circ$$

- **Conclusion**

For this system GM and PM are negative in values. Therefore the system is unstable in nature.

Polar plot

To sketch the polar plot of $G(j\omega)$ for the entire range of frequency ω , i.e., from 0 to infinity, there are four key points that usually need to be known:

- (1) the start of plot where $\omega = 0$,
- (2) the end of plot where $\omega = \infty$,
- (3) where the plot crosses the real axis, i.e., $\text{Im}(G(j\omega)) = 0$, and (4) where the plot crosses the imaginary axis, i.e., $\text{Re}(G(j\omega)) = 0$.

BASICS OF POLAR PLOT:

- The polar plot of a sinusoidal transfer function $G(j\omega)$ is a plot of the magnitude of $G(j\omega)$ Vs the phase of $G(j\omega)$ on polar co-ordinates as ω is varied from 0 to ∞ . (ie) $|G(j\omega)|$ Vs angle $G(j\omega)$ as $\omega \rightarrow 0$ to ∞ .
- Polar graph sheet has concentric circles and radial lines.
- Concentric circles represents the magnitude.
- Radial lines represents the phase angles.
- In polar sheet

0

+ve phase angle is measured in ACW from 0 -

0

ve phase angle is measured in CW from 0

PROCEDURE

- Express the given expression of OLTF in $(1+sT)$ form.
- Substitute $s = j\omega$ in the expression for $G(s)H(s)$ and get $G(j\omega)H(j\omega)$.
- Get the expressions for $|G(j\omega)H(j\omega)|$ & angle $G(j\omega)H(j\omega)$.
- Tabulate various values of magnitude and phase angles for different values of ω ranging from 0 to ∞ .
- Usually the choice of frequencies will be the corner frequency and around corner frequencies.
- Choose proper scale for the magnitude circles.
- Fix all the points in the polar graph sheet and join the points by a smooth curve. Write the frequency corresponding to each of the point of the plot.

MINIMUM PHASE SYSTEMS:

- Systems with all poles & zeros in the Left half of the s-plane – Minimum Phase Systems.

- For
- Minimum Phase Systems with only poles
 - Type No. determines at what quadrant the polar plot starts. Order
 - determines at what quadrant the polar plot ends.
 -
 - Type No. → No. of poles lying at the origin
 - Order → Max power of 's' in the denominator polynomial of the transfer function.

GAIN MARGIN

- Gain Margin is defined as —the factor by which the system gain can be increased to drive the system to the verge of instability.
- For stable systems,

$$\omega_{gc} < \omega_{pc}$$

Magnitude of $G(j\omega)H(j\omega)$ at $\omega = \omega_{pc} < 1$

GM = in positive dB

More positive the GM, more stable is the system.

- For marginally stable systems,

$$\omega_{gc} = \omega_{pc}$$

magnitude of $G(j\omega)H(j\omega)$ at $\omega = \omega_{pc} = 1$ GM
= 0 dB

For Unstable systems,

$$\omega_{gc} > \omega_{pc}$$

magnitude of $G(j\omega)H(j\omega)$ at $\omega = \omega_{pc} > 1$ GM
= in negative dB

Gain is to be reduced to make the system stable

Note:

- If the gain is high, the GM is low and the system's step response shows high overshoots and long settling time.
- On the contrary, very low gains give high GM and PM, but also causes higher ess, higher values of rise time and settling time and in general give sluggish response.
- Thus we should keep the gain as high as possible to reduce ess and obtain acceptable response speed and yet maintain adequate GM & PM.
- An adequate GM of 2 i.e. (6 dB) and a PM of 30 is generally considered good enough as a thumb rule.

0

At $\omega = \omega_{pc}$, angle of $G(j\omega)H(j\omega) = -180$

- Let magnitude of $G(j\omega)H(j\omega)$ at $\omega = \omega_{pc}$ be taken as B
- If the gain of the system is increased by factor $1/B$, then the magnitude of $G(j\omega)H(j\omega)$ at $\omega = \omega_{pc}$ becomes $B(1/B) = 1$ and hence the $G(j\omega)H(j\omega)$ locus pass through $-1+j0$ point driving the system to the verge of instability.
- GM is defined as the reciprocal of the magnitude of the OLTF evaluated at the phase cross over frequency.

$$\text{GM in dB} = 20 \log (1/B) = -20 \log B$$

PHASE MARGIN

Phase Margin is defined as — the additional phase lag that can be introduced before the system becomes unstable. Let A' be the point of intersection of $G(j\omega)H(j\omega)$ plot and a unit circle centered at the origin. Draw a line connecting the points O' & A' and measure the phase angle between the line OA and +ve real axis.

This angle is the phase angle of the system at the gain cross over frequency.

Angle of $G(j\omega_c)H(j\omega_c) = \phi_{gc}$

If an additional phase lag of ϕ PM is introduced at this frequency, then the phase angle $G(j\omega_c)H(j\omega_c)$ will become 180 and the point A coincides with $(-1+j0)$ driving the system to the verge of instability. This additional phase lag is known as the Phase Margin.

$$\gamma = 180^\circ + \text{angle of } G(j\omega_c)H(j\omega_c)$$

$$180^\circ + \phi_{gc}$$

[Since ϕ_{gc} is measured in CW direction, it is taken as negative]

For a stable system, the phase margin is positive.

- A Phase margin close to zero corresponds to highly oscillatory system.

- A polar plot may be constructed from experimental data or from a transfer function
- If the values of ω are marked along the contour, a polar plot has the same information as a bode plot.
- Usually, the shape of a polar plot is of most interest.

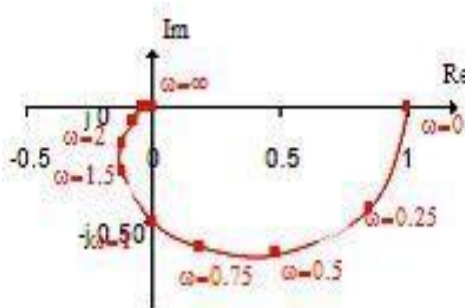

constructed from system transfer

marked along the contour, information as a bode plot.

a polar plot is of most

Frequency domain specifications

- The resonant peak M_r is the maximum value of $|M(j\omega)|$.
- The resonant frequency ω_r is the frequency at which the peak resonance M_r occurs.
- The bandwidth BW is the frequency at which $|M(j\omega)|$ drops to 70.7% (3 dB) of its zero frequency value.

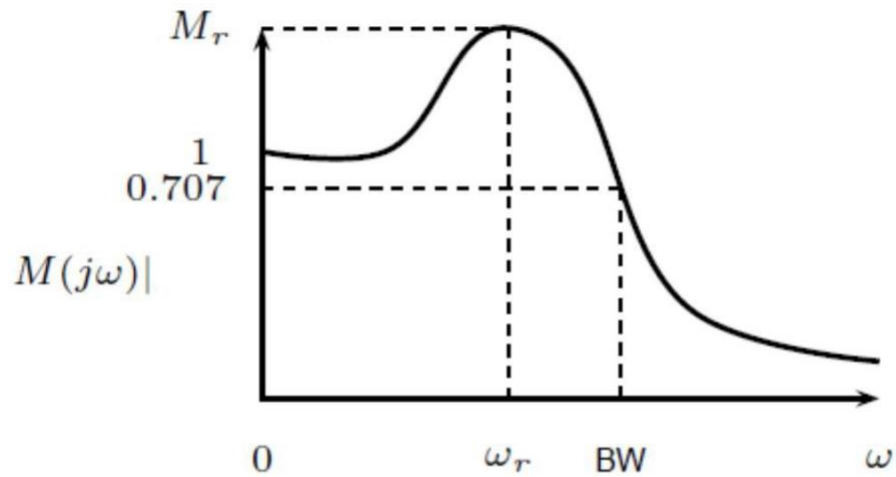

- M_r indicates the relative stability of a stable closed loop system.
 - A large M_r corresponds to larger maximum overshoot of the step response. Desirable value: 1.1 to 1.5
 - BW gives an indication of the transient response properties of a control system.
 - A large bandwidth corresponds to a faster rise time. BW and rise time t_r are inversely proportional.
- BW also
- indicates the noise-filtering characteristics and robustness of the system.
 - Increasing ω_n increases BW .
 - BW and M_r are proportional to each other.

TYPES OF COMPENSATION

- Series Compensation or Cascade Compensation

This is the most commonly used system where the controller is placed in series with the controlled process.

Figure shows the series compensation

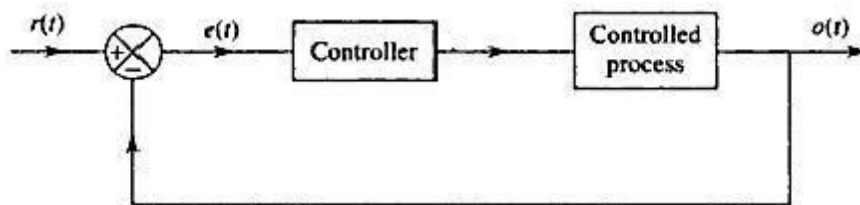

Series compensation.

Feedback compensation or Parallel compensation

This is the system where the controller is placed in the sensor feedback path as shown in

fig.

State

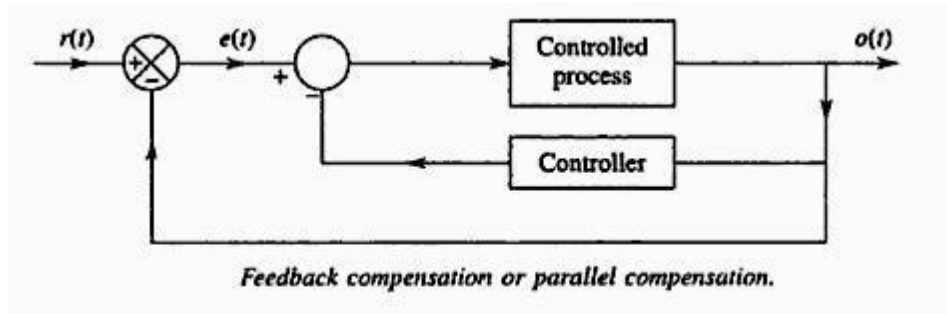

Feedback Compensation

This is a system which generates the control signal by feeding back the state variables through constant real gains. The scheme is termed state feedback. It is shown in Fig.

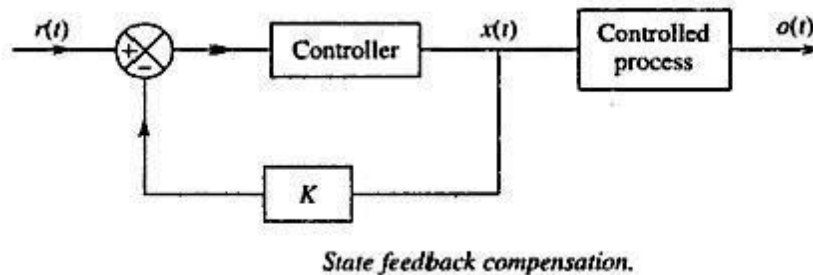

The compensation schemes shown in Figs above have one degree of freedom, since there is only one controller in each system. The demerit with one degree of freedom controllers is that the performance criteria that can be realized are limited.

That is why there are compensation schemes which have two degree freedoms, such as:

- (a) Series-feedback compensation
- (b) Feed forward compensation

Series -Feedback Compensation

Series-feedback compensation is the scheme for which a series controller and a feedback controller are used. Figure 9.6 shows the series -feedback compensation scheme.

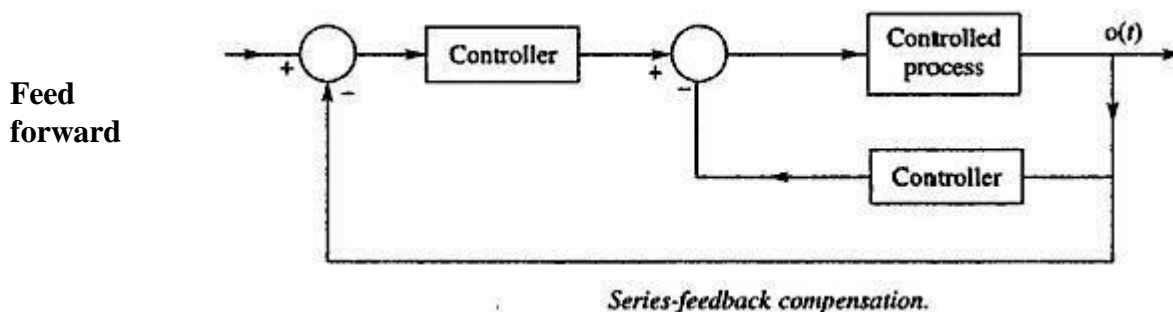

Feed
forward

Compensation

The feed forward controller is placed in series with the closed-loop system which has a controller in the forward path Orig. 9.71. In Fig. 9.8, Feed forward the is placed in parallel with the

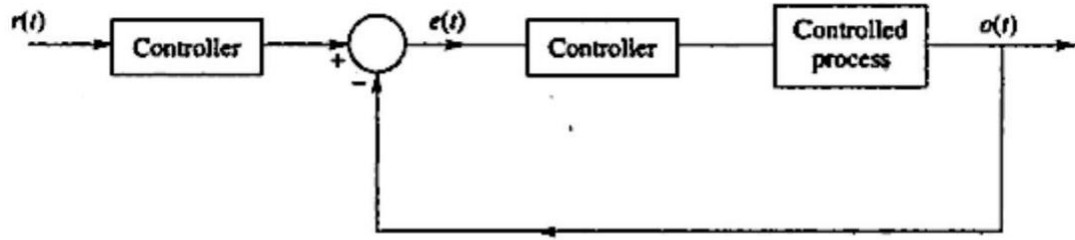

Feedforward controller in series with the closed-loop system.

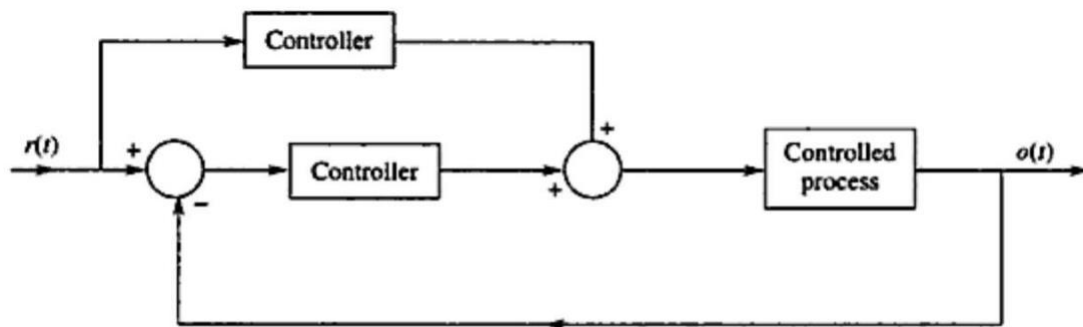

Feedforward controller in parallel with the controller in the forward path.

controller in the forward path. The commonly used controllers in the above-mentioned compensation schemes are now described in the section below.

Lead Compensator

It has a zero and a pole with zero closer to the origin. The general form of the transfer function of the lead compensator is

$$G(s) = \frac{s + \frac{1}{\tau}}{s + \frac{1}{\beta\tau}}$$

$$G(j\omega) = \beta \frac{(\tau j\omega + 1)}{\beta\tau j\omega + 1}$$

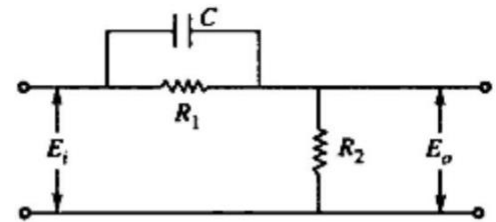

Lead compensator.

$$\begin{aligned} \frac{E_o(s)}{E_i(s)} &= \frac{R_2}{R_1 \times \frac{1}{Cs} + R_2 \left(R_1 + \frac{1}{Cs} \right)} = \frac{R_2 R_1 + \frac{R_2}{Cs}}{R_1 R_2 + \frac{1}{Cs} (R_1 + R_2)} \\ &= \frac{Cs R_1 R_2 + R_2}{Cs R_1 R_2 + R_1 + R_2} \\ &= \frac{R_2 (Cs R_1 + 1)}{(R_1 + R_2) \left(\frac{Cs R_1 R_2}{R_1 + R_2} + 1 \right)} \\ &= \left(\frac{R_2}{R_1 + R_2} \right) \frac{CR_1 s + 1}{\left(\frac{CR_1 R_2 s}{R_1 + R_2} + 1 \right)} \end{aligned}$$

Substituting

$$\tau = CR_1; \quad \beta\tau = \frac{CR_1 R_2}{R_1 + R_2} \quad (\because \tau = CR_1)$$

Transfer function

$$G(s) = \beta \frac{\tau s + 1}{\beta\tau s + 1}$$

Lag Compensator

It has a zero and a pole with the zero situated on the left of the pole on the negative real axis. The general form of the transfer function of the lag compensator is

$$G(s) = \frac{s + \frac{1}{\tau}}{s + \frac{1}{\alpha\tau}} = \frac{\alpha(\tau s + 1)}{\alpha\tau s + 1}$$

Therefore, the frequency response of f where $\alpha > 1$, $\tau > 0$. the above transfer function will be

$$G(j\omega) = \frac{\alpha(\tau j\omega + 1)}{\alpha\tau j\omega + 1}$$

$$E_o(s) = \frac{E_i(s)}{R_1 + R_2 + \frac{1}{Cs}} \left(R_2 + \frac{1}{Cs} \right)$$

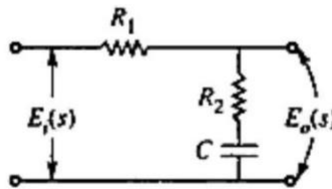

Lag compensator.

$$\begin{aligned} \frac{E_o(s)}{E_i(s)} &= \frac{R_2 + \frac{1}{Cs}}{R_1 + R_2 + \frac{1}{Cs}} \\ &= \frac{R_2Cs + 1}{(R_1 + R_2)Cs + 1} \end{aligned}$$

$$\begin{aligned} &= \frac{R_2C \left(s + \frac{1}{R_2C} \right)}{(R_1 + R_2)C \left(s + \frac{1}{(R_1 + R_2)C} \right)} \\ &= \frac{R_2}{(R_1 + R_2)} \frac{s + \frac{1}{R_2C}}{\left(s + \frac{1}{(R_1 + R_2)C} \right)} = \frac{R_2}{(R_1 + R_2)} \frac{\left(s + \frac{1}{R_2C} \right)}{\left(s + \frac{R_2}{(R_1 + R_2)R_2C} \right)} \end{aligned}$$

Now comparing with

$$G(s) = \frac{s + \frac{1}{\tau}}{s + \frac{1}{\alpha\tau}}$$

Therefore

$$\frac{1}{\tau} = \frac{1}{R_2 C}; \quad \frac{1}{\alpha \tau} = \frac{R_2}{(R_1 + R_2) R_2 C}$$

$$\frac{1}{\alpha \tau} = \frac{R_2}{(R_1 + R_2)} \frac{1}{\tau} \quad \left(\because \frac{1}{\tau} = \frac{1}{R_2 C} \right)$$

$$\alpha = \frac{R_1 + R_2}{R_2}$$

$$\frac{E_o(s)}{E_i(s)} = \frac{1}{\alpha} \frac{s + \frac{1}{\tau}}{s + \frac{1}{\alpha \tau}}$$

Lag-Lead Compensator

The lag-lead compensator is the combination of a lag compensator and a lead compensator. The lag-section is provided with one real pole and one real zero, the pole being to the right of zero, whereas the lead section has one real pole and one real zero with the zero being to the right of the pole.

The transfer function of the lag-lead compensator will be

$$G(s) = \left(\frac{s + \frac{1}{\tau_1}}{s + \frac{1}{\alpha \tau_1}} \right) \left(\frac{s + \frac{1}{\tau_2}}{s + \frac{1}{\beta \tau_2}} \right)$$

The figure shows lag lead compensator

$$E_o(s) = \frac{E_i(s)}{\frac{R_1 \times \frac{1}{sC_1}}{R_1 + \frac{1}{sC_1}} + R_2 + \frac{1}{sC_2}} \left(R_2 + \frac{1}{sC_2} \right)$$

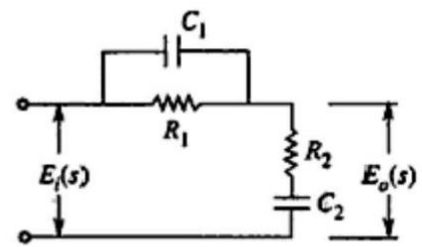

Lag-lead compensator.

where $\alpha > 1$, $\beta < 1$.

$$\begin{aligned}
\frac{E_o(s)}{E_i(s)} &= \frac{\left(R_1 + \frac{1}{sC_1}\right)\left(R_2 + \frac{1}{sC_2}\right)}{R_1 \frac{1}{sC_1} + \left(R_2 + \frac{1}{sC_2}\right)\left(R_1 + \frac{1}{sC_1}\right)} \\
&= \frac{\frac{(sC_1R_1 + 1)(sC_2R_2 + 1)}{sC_1 sC_2}}{\frac{R_1}{sC_1} + \frac{(R_2sC_2 + 1)(R_1sC_1 + 1)}{sC_2 sC_1}} \\
&= \frac{\frac{(1 + sC_1R_1)(1 + sC_2R_2)}{s^2C_1C_2}}{\frac{R_1sC_2 + R_2sC_2 + 1 + R_1R_2s^2C_1C_2 + R_1sC_1}{s^2C_1C_2}} \\
&= \frac{(1 + sC_1R_1)(1 + sC_2R_2)}{s^2R_1R_2C_1C_2 + s(R_1C_1 + R_2C_2) + 1 + R_1sC_2}
\end{aligned}$$

The above functions are with

transfer comparing

$$\begin{aligned}
&= \frac{C_1R_1 C_2R_2 \left(s + \frac{1}{C_1R_1}\right)\left(s + \frac{1}{C_2R_2}\right)}{R_1R_2C_1C_2 \left[s^2 + \left\{ \frac{1}{R_2C_2} + \frac{1}{R_1C_1} + \frac{1}{R_2C_1} \right\} s + \frac{1}{R_1R_2C_1C_2} \right]} \\
&= \frac{\left(s + \frac{1}{C_1R_1}\right)\left(s + \frac{1}{C_2R_2}\right)}{s^2 + \left(\frac{1}{R_1C_1} + \frac{1}{R_2C_1} + \frac{1}{R_2C_2}\right)s + \frac{1}{R_1R_2C_1C_2}} \\
G(s) &= \frac{\left(s + \frac{1}{\tau_1}\right)\left(s + \frac{1}{\tau_2}\right)}{\left(s + \frac{1}{\alpha\tau_1}\right)\left(s + \frac{1}{\beta\tau_2}\right)}
\end{aligned}$$

Then

$$\frac{1}{\tau_1} = \frac{1}{C_1R_1}, \quad \frac{1}{\tau_2} = \frac{1}{C_2R_2}$$

Therefore

$$\frac{1}{\alpha\tau_1} + \frac{1}{\beta\tau_2} = \frac{1}{R_1C_1} + \frac{1}{R_2C_1} + \frac{1}{R_2C_2}$$

$$\frac{1}{\alpha\beta\tau_1\tau_2} = \frac{1}{R_1R_2C_1C_2}$$

$$\tau_1 = C_1R_1$$

$$\tau_2 = C_2R_2$$

$$\alpha\beta\tau_1\tau_2 = R_1R_2C_1C_2$$

$$\alpha\beta = 1 \quad \text{or} \quad \beta = \frac{1}{\alpha}$$

$$G(s) = \frac{\left(s + \frac{1}{\tau_1}\right)\left(s + \frac{1}{\tau_2}\right)}{\left(s + \frac{1}{\alpha\tau_1}\right)\left(s + \frac{\alpha}{\tau_2}\right)} \quad \text{where } \alpha > 1$$

$$\frac{1}{R_1C_1} + \frac{1}{R_2C_1} + \frac{1}{R_2C_2} = \frac{1}{\alpha\tau_1} + \frac{\alpha}{\tau_2}$$

STABILITY AND COMPENSATOR DESIGN

Stability

A system is stable if any bounded input produces a bounded output for all bounded initial conditions.

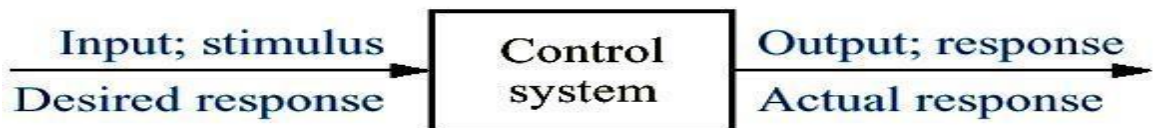

Basic concept of stability

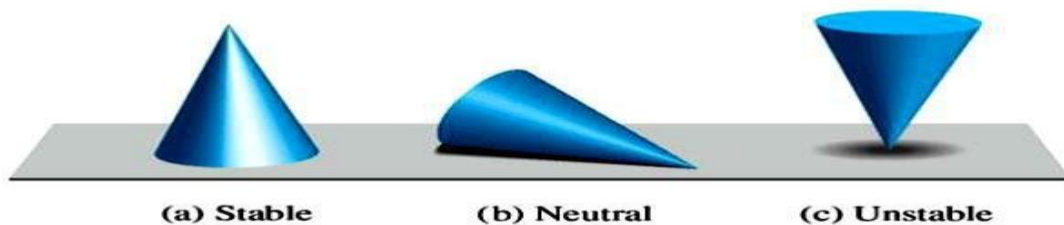

Stability of the system and roots of characteristic equations

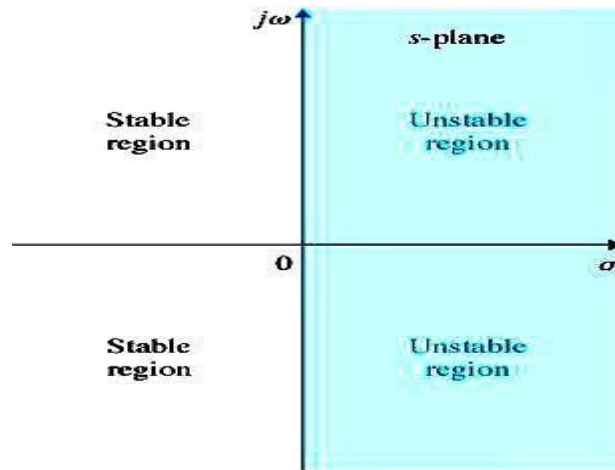

Characteristic Equation

Consider an nth-order system whose the characteristic equation (which is also the denominator of the transfer function) is

$$a(S) = S^n + a_1 S^{n-1} + a_2 S^{n-2} + \dots + a_{n-1} S + a_0 S^0$$

Routh Hurwitz Criterion

Goal: Determining whether the system is stable or unstable from a characteristic equation in polynomial form without actually solving for the roots Routh's stability criterion is useful for determining the ranges of coefficients of polynomials for stability, especially when the coefficients are in symbolic (non numerical) form. To find K mar & ω

A necessary condition for Routh's Stability

- A necessary condition for stability of the system is that all of the roots of its characteristic equation have negative real parts, which in turn requires that all the coefficients be positive.
- A necessary (but not sufficient) condition for stability is that all the coefficients of the polynomial characteristic equation are positive & none of the co-efficient vanishes.
- Routh's formulation requires the computation of a triangular array that is a function of the coefficients of the polynomial characteristic equation.
- A system is stable if and only if all the elements of the first column of the Routh array are positive

Method for determining the Routh array

Consider the characteristic equation

$$a(S) = 1X S^n + a_1 S^{n-1} + a_2 S^{n-2} + \dots + a_{n-1} S + a_0 S^0$$

Routh array method

Then add subsequent rows to complete the Routh array

Compute elements for the

3rd row:

$$b_1 = -\frac{1 \times a_3 - a_2 a_1}{a_1}$$

Given the characteristic

$$b_2 = -\frac{1 \times a_5 - a_4 a_1}{a_1}$$

equation ,

$$b_3 = -\frac{1 \times a_7 - a_6 a_1}{a_1}$$

$$a(s) = s^6 + 4s^5 + 3s^4 + 2s^3 + s^2 + 4s + 4$$

Is the system described by this stable?

...

characteristic equation

Answer:

- All the coefficients are positive and nonzero
- Therefore, the system satisfies the necessary condition for stability
- We should determine whether any of the coefficients of the first column of the Routh array are negative.

s^6 :	1	3	1	4				
s^5 :	4	2	4	0				
s^4 :	5/2	0	4					
s^3 :	2	-12/5	0					
S :	s^2 :	?	?		6	1	3	1
4	s^1 :	?	?		5			
S :	s^0 :	?			4	2	4	
0								
4	S :	5/2	0	4				
3	S :	2	-12/5	0				
2	S :	3	4					
1	S :	-76/15	0					
0	S :	4						

The elements of the 1st column are not all positive. Then the system is unstable

Special cases of Routh's criteria:

Case 1: All the elements of a row in a RA are zero

- Form Auxiliary equation by using the co-efficient of the row which is just above the row of zeros.

- Find derivative of the A.E.
- Replace the row of zeros by the co-efficient of
- $dA(s)/ds$ Complete the array in terms of these
- coefficients. analyze for any sign change, if so,
- unstable no sign change, find the nature of roots of AE
- non-repeated imaginary roots - marginally stable
- repeated imaginary roots – unstable

Case 2:

- First element of any of the rows of RA is
- Zero and the same remaining row contains atleast one non-zero element
- Substitute a small positive no. $\underline{\underline{\epsilon}}$ in place of zero and complete the array.
- Examine the sign change by taking $\text{Lt } \epsilon = 0$

Nyquist Stability Criteria:

The Routh-Hurwitz criterion is a method for determining whether a linear system is stable or not by examining the locations of the roots of the characteristic equation of the system. In fact, the method determines only if there are roots that lie outside of the left half plane; it does not actually compute the roots. Consider the characteristic equation.

To determine whether this system is stable or not, check the following conditions

$$1 + GH(s) = D(s) = a_n s^n + a_{n-1} s^{n-1} + \dots + a_1 s + a_0 = 0$$

1. Two necessary but not sufficient conditions that all the roots have negative real parts are a) All the polynomial coefficients must have the same sign. b) All the polynomial coefficients must be nonzero.
2. If condition (1) is satisfied, then compute the Routh-Hurwitz array as follows

Where the polynomial coefficients, rest of the coefficients computed using the following

s^n	a_n	a_{n-2}	a_{n-4}	a_{n-6}	\dots	$a_i S^i$ are
s^{n-1}	a_{n-1}	a_{n-3}	a_{n-5}	a_{n-7}	\dots	
s^{n-2}	b_1	b_2	b_3	\dots	\dots	and the
s^{n-3}	c_1	c_2	c_3	\dots	\dots	in the
s^{n-4}	\vdots	\vdots	\vdots	\vdots	\vdots	table are
\vdots	\vdots	\vdots	\vdots	\vdots	\vdots	pattern
s^1	\vdots	\vdots	\vdots	\vdots	\vdots	
s^0	\vdots	\vdots	\vdots	\vdots	\vdots	

$$b_1 = \frac{-1}{a_{n-1}} \begin{vmatrix} a_n & a_{n-2} \\ a_{n-1} & a_{n-3} \end{vmatrix} = \frac{-1}{a_{n-1}} (a_n a_{n-3} - a_{n-2} a_{n-1})$$

$$b_2 = \frac{-1}{a_{n-1}} \begin{vmatrix} a_n & a_{n-4} \\ a_{n-1} & a_{n-5} \end{vmatrix}$$

$$b_3 = \frac{-1}{a_{n-1}} \begin{vmatrix} a_n & a_{n-6} \\ a_{n-1} & a_{n-7} \end{vmatrix} \dots$$

$$c_1 = \frac{-1}{b_1} \begin{vmatrix} a_{n-1} & a_{n-3} \\ b_1 & b_2 \end{vmatrix}$$

$$c_2 = \frac{-1}{b_1} \begin{vmatrix} a_{n-1} & a_{n-5} \\ b_1 & b_3 \end{vmatrix} \dots$$

3. The necessary condition that all roots have negative real parts is that all the elements of the first column of the array have the same sign. The number of changes of sign equals the number of roots with positive real parts.
4. Special Case 1: The first element of a row is zero, but some other elements in that row are nonzero. In this case, simply replace the zero elements by " ", complete the table development, and then interpret the results assuming that " " is a small number of the same sign as the

element above it. The results must be interpreted in the limit as ϵ to 0.

5. Special Case 2: All the elements of a particular row are zero. In this case, some of the roots of the polynomial are located symmetrically about the origin of the s -plane, e.g., a pair of purely imaginary roots. The zero rows will always occur in a row associated with an odd power of s . The row just above the zero rows holds the coefficients of the auxiliary polynomial. The roots of the auxiliary polynomial are the symmetrically placed roots. Be careful to remember that the coefficients in the array skip powers of s from one coefficient to the next.

Let P = no. of poles of $q(s)$ -plane lying on Right Half of s -plane and encircled by s -plane contour.

Let Z = no. of zeros of $q(s)$ -plane lying on Right Half of s -plane and encircled by s -plane contour.

For the CL system to be stable, the no. of zeros of $q(s)$ which are the CL poles that lie in the right half of s -plane should be zero. That is $Z = 0$, which gives $N = -P$.

Therefore, for a stable system the no. of ACW encirclements of the origin in the $q(s)$ -plane by the contour C_q must be equal to P .

Nyquist modified stability criteria

We know that $q(s) = 1 + G(s)H(s)$

Therefore $G(s)H(s) = [1 + G(s)H(s)] - 1$

- The contour C_q , which has obtained due to mapping of Nyquist contour from s -plane to $q(s)$ -plane (ie) $[1 + G(s)H(s)]$ -plane, will encircle about the origin.
- The contour C_{GH} , which has obtained due to mapping of Nyquist contour from s -plane to $G(s)H(s)$ -plane, will encircle about the point $(-1 + j0)$.
- Therefore encircling the origin in the $q(s)$ -plane is equivalent to encircling the point $-1 + j0$ in the $G(s)H(s)$ -plane.

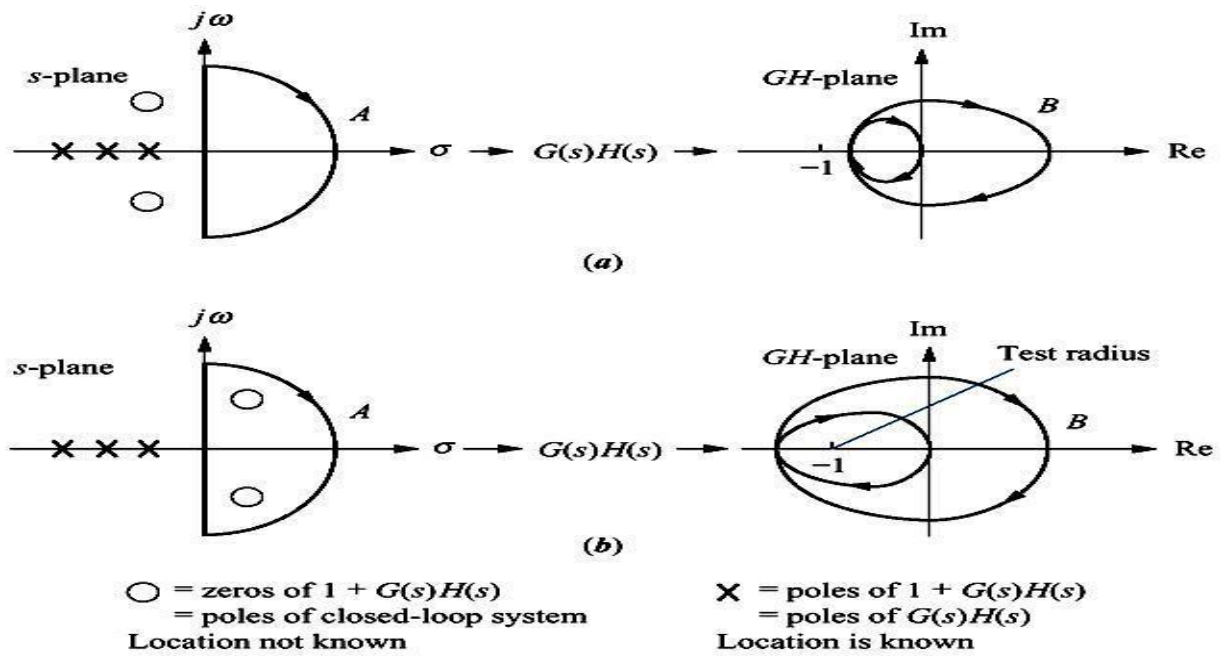

Problem

Sketch the Nyquist stability plot for a feedback system with the following open-loop transfer function

$$G(s)H(s) = \frac{1}{s(s^2 + s + 1)}$$

Solution

For section ab, $s = j\omega$, $\omega : 0 \rightarrow \infty$

$$G(j\omega)H(j\omega) = \frac{1}{j\omega(1 - \omega^2 + j\omega)}$$

(i) $\omega \rightarrow 0 : G(j\omega)H(j\omega) \rightarrow -1 - j\infty$

(ii) $\omega = 1 : G(j\omega)H(j\omega) \rightarrow -1 + j0$

(iii) $\omega \rightarrow \infty : G(j\omega)H(j\omega) \rightarrow 0 \angle -270^\circ$

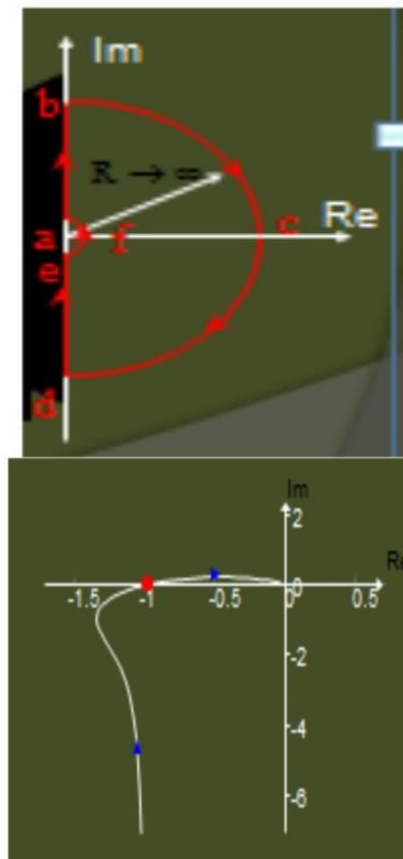

On section bcd, $s = Re^{j\theta} |_{R \rightarrow \infty}$; therefore i.e. section bcd maps onto the origin of the $G(s)H(s)$ -plane

$$|G(s)H(s)| \rightarrow \frac{1}{R^3} \rightarrow 0$$

Section de maps as the complex image of the polar plot as before

Relative stability

The main disadvantage to draw and consider two namely, magnitude plot and contained in these two plots can polar plot. The polar plot is for a while the Nyquist plot is in the The information on the negative because the magnitude and real In this section. We consider how to evaluate the system performance in terms of relative stability using a Nyquist plot. The open-loop system represented by this plot will become unstable beyond a certain value. As shown in the Nyquist plot of Fig. the intercept of magnitude 'a' on the negative real axis corresponds lost phase shift of -180° and -1 represents the amount of increase in gain that can be tolerated before closed-loop system tends toward instability. As 'a' approaches $(-1+j0)$ point the relative stability is reduced; the gain and phase margins are represented as follows in the Nyquist plot.

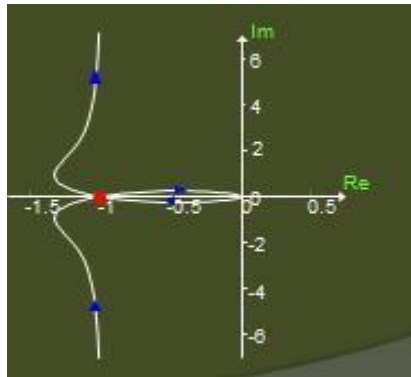

of a Bode plot is that we have different curves at a time, phase plot. Information be combined into one named frequency range of $0 < \omega < \alpha$. frequency range of $-\alpha < \omega < \alpha$. frequency is redundant part of $G(j\omega)$ and are even functions.

Gain margin

As system gain is increased by a factor $1/a$, the open loop magnitude of $G(j\omega)H(j\omega)$ will increase by a factor $a(1/a) = 1$ and the system would be driven to instability. Thus, the gain margin is the reciprocal of the gain at the frequency at which the phase angle of the Nyquist plot

is -180° . The gain margin, usually measured in dB, is a positive quantity given by

$$GM = -20 \log a \text{ dB}$$

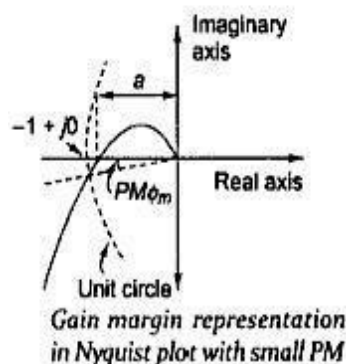

Phase Margin ϕ_m

Importance of the phase margin has already in the content of Bode. Phase margin is defined as the change in open-loop phase shift required at unity gain to make a closed loop system unstable. A closed-loop system will be unstable if the Nyquist plot encircles $-1 + j0$ point. Therefore, the angle required to make this system marginally stable in a closed loop is the phase margin. In order to measure this angle, we draw a circle with a radius of 1, and find the point of intersection of the Nyquist plot with this circle, and measure the phase shift needed for this point to be at an angle of 180° . It may be appreciated that the system having plot of Fig with larger PM is more stable than the one with plot of Fig.

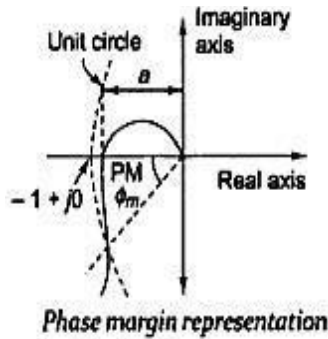

UNIT 5 STATE VARIABLE ANALYSIS

State space representation of Continuous Time systems

The state variables may be totally independent of each other, leading to diagonal or normal form or they could be derived as the derivatives of the output. If there is no direct relationship between various states. We could use a suitable transformation to obtain the representation in diagonal form.

Phase Variable Representation

It is often convenient to consider the output of the system as one of the state variables and remaining state variables as derivatives of this state variable. The state variables thus obtained from one of the system variables and its (n-1) derivatives, are known as n-dimensional phase variables.

In a third-order mechanical system, the output may be displacement x_1 , $x_1 = x_2 = v$ and $x_2 = x_3 = a$ in the case of motion of translation or angular displacement θ , $\theta = x_1$, $x_1 = x_2 = w$ and $x_2 = x_3 = \alpha$ if the motion is rotational, Where v, w, a, α respectively, are velocity, angular velocity, acceleration, angular acceleration.

Consider a SISO system described by nth -order differential equation.

$$y^{(n)}(t) + a_1 y^{(n-1)}(t) + \dots + a_{n-1} y'(t) + a_n y(t) = Ku$$

Where

$$y^{(n)}(t) = d^n y(t)/dt^n,$$

u is, in general, a function of time.

The nth order transfer function of this system is

$$G(s) = \frac{y(s)}{u(s)} = \frac{K}{s^n + a_1 s^{n-1} + \dots + a_{n-1} s + a_n}$$

With the states (each being function of time) be defined as

$$x_1 = y(t), \quad x_2 = \dot{y}(t), \quad x_3 = \ddot{y}(t), \quad \dots, \quad x_n = y^{(n-1)}(t),$$

Equation becomes

Using above Eqs state
 atiable loan can he

$$\begin{aligned} \dot{x}_n + a_1 x_n + a_2 x_{n-1} + \dots + a_{n-1} x_2 + a_n x_1 &= Ku(t) \\ \dot{x}_n &= -a_1 x_n - a_2 x_{n-1} - \dots - a_{n-1} x_2 - a_n x_1 + Ku \end{aligned}$$

equations in phase s
 obtained as

$$\dot{\mathbf{x}} = \begin{bmatrix} \dot{x}_1 \\ \dot{x}_2 \\ \vdots \\ \dot{x}_n \end{bmatrix} = \begin{bmatrix} 0 & 1 & 0 & \dots & 0 & 0 \\ 0 & 0 & 1 & \dots & 0 & 0 \\ \dots & \dots & \dots & \dots & \dots & \dots \\ 0 & 0 & 0 & \dots & 0 & 1 \\ -a_n & -a_{n-1} & -a_{n-2} & \dots & a_2 & -a_1 \end{bmatrix} \begin{bmatrix} x_1 \\ x_2 \\ \vdots \\ x_n \end{bmatrix} + \begin{bmatrix} 0 \\ 0 \\ \vdots \\ 0 \\ K \end{bmatrix} u$$

Where

Physical Variable Representation

$$y = [1 \ 0 \ 0 \ \dots \ 0] \mathbf{x}$$

In this representation the state
 which can be measured and used for

$$\mathbf{x} = [x_1 \ x_2 \ \dots \ x_n]^T$$

variables are real physical variables,
 manipulation or for control purposes.

The approach generally adopted is to break the block diagram of the transfer function into subsystems in such a way that the physical variables can he identified. The governing equations for the subsystems can he used to identify the physical variables. To illustrate the a pproach consider the block diagram of Fig.

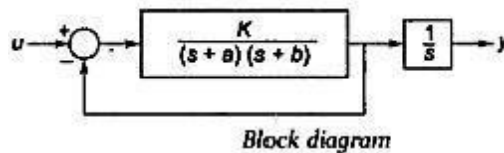

Block diagram

One may represent the transfer function of this system as

$$T(s) = \frac{y(s)}{u(s)} = \frac{K}{K + (s+a)(s+b)} \cdot \frac{1}{s} = \frac{G(s)}{1 + G(s)H(s)} \cdot \frac{1}{s} = \frac{K / (s+a)(s+b)}{1 + K / (s+a)(s+b)} \cdot \frac{1}{s}$$

Taking H(s) = 1, the block diagram of can be redrawn as in Fig. physical variables can be speculated as x1=y, output, x2 =w= θ the angular velocity x3 = Ia the armature current in a position -control system.

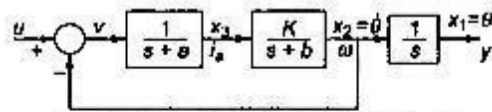

(a = R_a/L_{a}, b = f/J and K = 1/JL_{a} in Prob. 8)}}

Block diagram with physical variables

Where

$$x_1 = y, \dot{s} x_1 = x_2, v = (s + a) x_3$$

The state space representation can be obtained by

$$\dot{x}_1 = x_2, \dot{x}_2 = -bx_2 + Kx_3, \dot{x}_3 = -ax_3 - x_2 + u, y = x_1$$

$$\begin{bmatrix} \dot{x}_1 \\ \dot{x}_2 \\ \dot{x}_3 \end{bmatrix} = \begin{bmatrix} 0 & 1 & 0 \\ 0 & -b & K \\ 0 & -1 & -a \end{bmatrix} \begin{bmatrix} x_1 \\ x_2 \\ x_3 \end{bmatrix} + \begin{bmatrix} 0 \\ 0 \\ 1 \end{bmatrix} u$$

And

$$y(t) = [1 \ 0 \ 0] \begin{bmatrix} x_1 \\ x_2 \\ x_3 \end{bmatrix}$$

Solution of State equations

Consider the state equation n of linear time invariant system as,

$$\dot{X}(t) = AX(t) + BU(t)$$

The matrices A and B are constant matrices. This state equation can be of two types,

1. Homogeneous and
2. Non homogeneous

Homogeneous Equation

If A is a constant matrix and input control forces are zero then the equation takes the form,

$$\dot{X}(t) = A X(t)$$

Such an equation is called homogeneous equation. The obvious equation is if input is zero, In such systems, the driving force is provided by the initial conditions of the system to produce the output. For example, consider a series RC circuit in which capacitor is initially charged to V volts. The current is the output. Now there is no input control force i.e. external voltage applied to the system. But the initial voltage on the capacitor drives the current through the system and capacitor starts discharging through the resistance R. Such a system which works on the initial conditions without any input applied to it is called homogeneous system.

Non homogeneous Equation

If A is a constant matrix and matrix U(t) is non-zero vector i.e. the input control forces are applied to the system then the equation takes normal form as,

$$\dot{X}(t) = A X(t) + B U(t)$$

Such an equation is called non homogeneous equation. Most of the practical systems require inputs to drive them. Such systems are non homogeneous linear systems. The solution of the state equation is obtained by considering basic method of finding the solution of homogeneous equation.

Controllability and Observability

More specially, for system of Eq.(1), there exists a similar transformation that will diagonalize the system. In other words, There is a transformation matrix Q such that

$$\dot{X} = AX + Bu \quad ; \quad y = CX + Du \quad ; \quad X(0) = X_0 \quad (1)$$

$$\hat{X} = QX \quad \text{or} \quad X = Q^{-1}\hat{X} \quad (2)$$

$$\dot{\hat{X}} = \Lambda\hat{X} + \hat{B}u \quad y = \hat{C}\hat{X} + \hat{D}u \quad (3)$$

$$\text{Where } \Lambda = \begin{bmatrix} \lambda_1 & 0 & \dots & 0 \\ 0 & \lambda_2 & \dots & 0 \\ & & \ddots & \\ 0 & & \dots & \lambda_n \end{bmatrix} \quad (4)$$

Notice that by doing the diagonalizing transformation, the resulting transfer function between $u(s)$ and $y(s)$ will not be altered.

$$\hat{b}_k = 0, \text{ then } x_k(t) = e^{-\lambda_k t} x_k(0_-)$$

The lack of controllability of the state $x_k(t)$ is reflected by a zero k^{th} row of B , i.e. b_k . Which would cause a complete zero row in the following matrix (known as the controllability matrix), i.e.:

Looking at Eq.(3), if $x_k(t)$ is uncontrollable by the input $u(t)$, since, $x_k(t)$ is characterized by the mode

$$C(A,b) = \begin{bmatrix} \hat{B} & \hat{A}\hat{B} & \hat{A}^2\hat{B} & \hat{A}^3\hat{B} & \dots & \hat{A}^{n-1}\hat{B} \end{bmatrix} \dots = \begin{bmatrix} \hat{b}_1 & \lambda_1\hat{b}_1 & \lambda_1^2\hat{b}_1 & \dots & \lambda_1^{n-1}\hat{b}_1 \\ \hat{b}_2 & \lambda_2\hat{b}_2 & \lambda_2^2\hat{b}_2 & \dots & \lambda_2^{n-1}\hat{b}_2 \\ \dots & \dots & \dots & \dots & \dots \\ \hat{b}_k & \lambda_k\hat{b}_k & \lambda_k^2\hat{b}_k & \dots & \lambda_k^{n-1}\hat{b}_k \\ \dots & \dots & \dots & \dots & \dots \\ \hat{b}_n & \lambda_n\hat{b}_n & \lambda_n^2\hat{b}_n & \dots & \lambda_n^{n-1}\hat{b}_n \end{bmatrix} \quad (5)$$

A $C(A,b)$ matrix with all non-zero row has a rank of N .

In fact, $B = Q^{-1}\hat{B}$ or $\hat{B} = QB$. Thus, a non-singular $C(A,b)$ matrix implies a non-singular matrix of $C(A,b)$ of the following:

$$C(A,b) = \begin{bmatrix} B & AB & A^2B & \dots & A^{n-1}B \end{bmatrix}$$

Transfer function from State Variable Representation

A simple example of system has an input and output as shown in Figure 1. This class of system has general form of model given in Eq.(1).

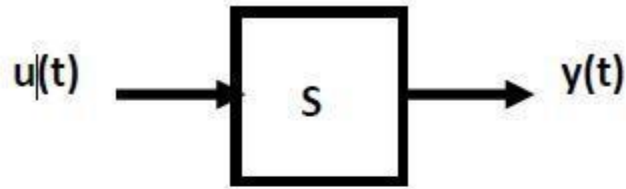

$$\frac{d^n y}{dt^n} + a_{n-1} \frac{d^{n-1} y}{dt^{n-1}} + \dots + a_0 y(t) = b_{m-1} \frac{d^{m-1} u}{dt^{m-1}} + \dots + b_0 u(t)$$

Models of this form have the property of the following:

$$u(t) = \alpha_1 u_1(t) + \alpha_2 u_2(t) \Rightarrow y(t) = \alpha_1 y_1(t) + \alpha_2 y_2(t) \quad (2)$$

where, (y_1, u_1) and (y_2, u_2) each satisfies Eq.(1).

Model of the form of Eq.(1) is known as linear time invariant (abbr. **LTI**) system. Assume the system is at rest prior to the time $t_0=0$, and, the input $u(t)$ ($0 < t < \infty$) produces the output $y(t)$ ($0 < t < \infty$), the model of Eq.(1) can be represented by a transfer function in term of Laplace transform variables, i.e.:

$$y(s) = \frac{b_m s^m + b_{m-1} s^{m-1} + \dots + b_0}{a_n s^n + a_{n-1} s^{n-1} + \dots + a_0} u(s) \quad (3)$$

Then applying the same input shifted by any amount q of time produces the same output shifted by the same amount q of time. The representation of this fact is given by the following transfer function:

$$y(s) = \left(\frac{b_m s^m + b_{m-1} s^{m-1} + \dots + b_0}{a_n s^n + a_{n-1} s^{n-1} + \dots + a_0} \right) e^{-s q} u(s) \quad (4)$$

Models of Eq.(1) having all $b_i = 0$ ($i > 0$), a state space description arose out of a reduction to a system of first order differential equations. This technique is quite general. First, Eq.(1) is written as:

$$y^{(n)} = f(t, u(t), y, \dot{y}, \ddot{y}, \dots, y^{(n-1)}); \quad (5)$$

with initial conditions: $y(0)=y_0, \dot{y}(0)=y_1(0), \dots, y^{(n-1)}(0)=y_{n-1}(0)$

Consider the vector $x \in R^n$ with $x_1 = y, x_2 = \dot{y}, x_3 = \ddot{y}, \dots, x_n = y^{(n-1)}$, Eq.(5) becomes:

$$\frac{d}{dt} X = \begin{bmatrix} x_2 \\ x_3 \\ \vdots \\ x_n \\ f(t, u(t), y, \dot{y}, \ddot{y}, \dots, y^{(n-1)}) \end{bmatrix} \quad (6)$$

In case of linear system, Eq.(6) becomes:

$$\frac{d}{dt} X = \begin{bmatrix} 0 & 1 & 0 & \dots & \dots & 0 \\ 0 & 0 & 1 & 0 & \dots & 0 \\ & & & \ddots & & \\ 0 & 0 & \dots & \ddots & & 1 \\ -a_0 & -a_1 & \dots & -a_{n-1} & & \end{bmatrix} X + \begin{bmatrix} 0 \\ 0 \\ \vdots \\ 0 \\ 1 \end{bmatrix} u(t); \quad y(t) = \begin{bmatrix} 1 & 0 & 0 & \dots & 0 \end{bmatrix} X \quad (7)$$

It can be shown that the general form of Eq.(1) can be written as

$$\frac{d}{dt} X = \begin{bmatrix} 0 & 1 & 0 & \dots & \dots & 0 \\ 0 & 0 & 1 & 0 & \dots & 0 \\ & & & \ddots & & \\ 0 & 0 & \dots & \ddots & & 1 \\ -a_0 & -a_1 & \dots & -a_{n-1} & & \end{bmatrix} X + \begin{bmatrix} 0 \\ 0 \\ \vdots \\ 0 \\ 1 \end{bmatrix} u(t); \quad y(t) = \begin{bmatrix} b_0 & b_1 & \dots & b_m & 0 & \dots & 0 \end{bmatrix} X \quad (8)$$

and, will be represented in an abbreviation form:

$$\dot{X} = AX + Bu; \quad y = CX + Du; \quad D=0 \quad (9)$$

Eq.(9) is known as the controller canonical form of the system.

State space representation for discrete time systems

The dynamics of a linear time (shift) invariant discrete-time system may be expressed in terms state (plant) equation and output (observation or measurement) equation as follows

$$\begin{aligned} \mathbf{x}(k+1) &= \mathbf{A}\mathbf{x}(k) + \mathbf{B}\mathbf{u}(k), \\ \mathbf{y}(k) &= \mathbf{C}\mathbf{x}(k) + \mathbf{D}\mathbf{u}(k) \end{aligned}$$

Where $\mathbf{x}(k)$ an n dimensional state vector at time $t = kT$, an r -dimensional control (input) vector $\mathbf{y}(k)$, an m -dimensional output vector, respectively, are represented as

$$\mathbf{x}(k) = [x_1(k), x_2(k), \dots, x_n(k)]^T, \quad \mathbf{u}(k) = [u_1(k), u_2(k), \dots, u_r(k)]^T, \quad \mathbf{y}(k) = [y_1(k), y_2(k), \dots, y_m(k)]^T.$$

The parameters (elements) of A , an $n \times n$ (plant parameter) matrix. B an $n \times r$ control (input) matrix, and C An $m \times n$ output parameter, D an $m \times r$ parametric matrix are constants for the LTI system. Similar to above equation state variable representation of SISO (single output and single input) discrete-time system (with direct coupling of output with input) can be written as

$$\begin{aligned} \mathbf{x}(k+1) &= A\mathbf{x}(k) + b\mathbf{u}(k) \\ y(k) &= \mathbf{c}^T \mathbf{x}(k) + d\mathbf{u}(k) \end{aligned}$$

Where the input u , output y and d . are scalars, and b and c are n -dimensional vectors. The concepts of controllability and observability for discrete time system are similar to the continuous-time system. A discrete time system is said to be controllable if there exists a finite integer n and input $u(k); k \in [0, n-1]$ that will transfer any state $x(0)$ to the state x at $k = n$.

Sampled Data System

When the signal or information at any or some points in a system is in the form of discrete pulses. Then the system is called discrete data system. In control engineering the discrete data system is popularly known as sampled data systems.

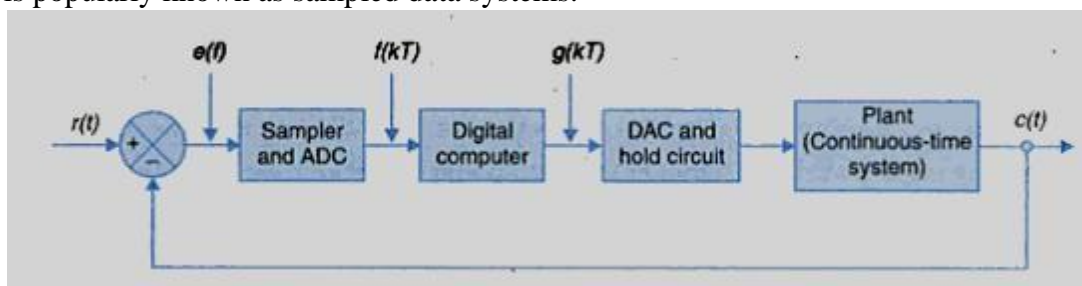

Sampling Theorem

A band limited continuous time signal with highest frequency f_m hertz can be uniquely recovered from its samples provided that the sampling rate F_s is greater than or equal to $2f_m$ samples per seconds.

Sample & Hold

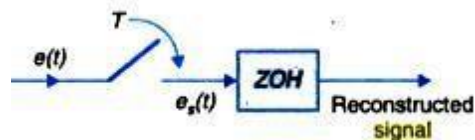

The Signal given to the digital controller is a sampled data signal and in turn the controller gives the controller output in digital form. But the system to be controlled needs an analog control signal as input. Therefore the digital output of controllers must be converted into analog form.

This can be achieved by means of various types of hold circuits. The simplest hold circuits are the zero order hold (ZOH). In ZOH, the reconstructed analog signal acquires the same values as the last received sample for the entire sampling period.

The high frequency noises present in the reconstructed signal are automatically filtered out by the low pass component of the control system. In a first order hold the last two current sampling signals for the period are held. Similarly, higher order hold circuits can be devised. First or higher order hold circuits offer no particular advantage over the zero order hold.

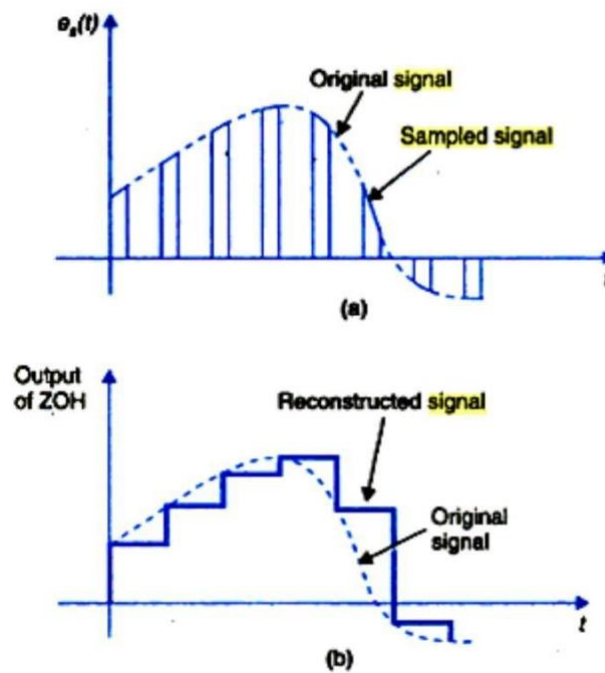

frequency noises reconstructed signal filtered out by the component which filters. In a first signals for the period. Similarly circuit can be order hold circuits advantage over the

QUESTION BANK

UNIT-I SYSTEMS AND THEIR REPRESENTATION

PART-A

1. What is control system?

A system consists of a number of components connected together to perform a specific function. In a system when the output quantity is controlled by varying the input quantity then the system is called control system.

2. Define open loop control system.

The control system in which the output quantity has no effect upon the input quantity is called open loop control system. This means that the output is not feedback to the input for correction.

3. Define closed loop control system.

The control system in which the output has an effect upon the input quantity so as to maintain the desired output values are called closed loop control system.

4. What are the components of feedback control system?

The components of feedback control system are plant, feedback path elements, error detector actuator and controller.

5. Distinguish between open loop and closed loop system

S.No	Open Loop	Closed Loop
1	Inaccurate	Accurate
2	Simple and Economical	Complex and Costlier
3	The change in output due to external disturbance are not corrected	The change in output due to external disturbance are corrected automatically
4	May oscillate and become un stable	They are generally stable

6. Define transfer function.

The Transfer function of a system is defined as the ratio of the laplace transform of output to Laplace transform of input with zero initial conditions.

7. What are the basic elements used for modeling mechanical translational system.

- Mass M, Kg,

Stiffness of spring K, N/m • and Viscous friction coefficient dashpot B, N-sec/m

8. What are the basic elements used for modeling mechanical rotational system?

- Moment of inertia J, Kg-m
- /rad dashpot with rotational frictional coefficient B, N-
- m/(rad/sec) And torsional spring with stiffness K ,N-m /rad.

9. Name two types of electrical analogous for mechanical system.

The two types of analogies for the mechanical system are

- Force voltage and
- Force current analogy

10. What is block diagram?

A block diagram of a system is a pictorial representation of the functions performed by each component of the system and shows the flow of signals.

11. What are the basic components of Block diagram?

The basic elements of block diagram are blocks, branch point and summing point.

12. What is the basis for framing the rules of block diagram reduction technique?

The rules for block diagram reduction technique are framed such that any modification made on the diagram does not alter the input output relation.

13. What is a signal flow graph?

A signal flow graph is a diagram that represents a set of simultaneous algebraic equations. By taking Laplace Transform the time domain differential equations governing a control system can be transferred to a set of algebraic equations in s-domain.

14. What is transmittance?

The transmittance is the gain acquired by the signal when it travels from one node to another node in signal flow graph.

15. What is sink and source?

Source is the input node in the signal flow graph and it has only outgoing branches. Sink is a output node in the signal flow graph and it has only incoming branches.

16. Define non touching loop.

The loops are said to be non touching if they do not have common nodes.

17. Write Masons Gain formula.

Mason's gain formula states that the overall gain of the system as follows Overall gain,

$T = T(S)$ = transfer function of the system

K = Number of forward path in the signal flow.

P_K = forward path gain of the K th forward path

$\Delta = 1 - (\text{Sum of individual loop gains}) + (\text{Sum of gain products of all possible combinations of two non touching loops}) - (\text{Sum of gain products of all possible combinations of three non touching loops}) + \dots\dots$

$\Delta_k = (\Delta \text{ for that part of the graph which is not touching } K\text{th forward path})$

18. Write the analogous electrical elements in force voltage analogy for the elements of mechanical translational system.

Force, $f \rightarrow$ Voltage, e

Velocity, $V \rightarrow$ current, i

Displacement, $x \rightarrow$ charge, q

Frictional coefficient, $B \rightarrow$ Resistance, R

Mass, $M \rightarrow$ inductance, L

Stiffness, $K \rightarrow$ Inverse of capacitance $1/C$

Newton's second law \rightarrow Kirchhoff's voltage law.

19. Write the analogous electrical elements in force current analogy for the elements of mechanical translational system.

Force, $f \rightarrow$ current, i

Velocity, $V \rightarrow$ Voltage, e

Displacement, $x \rightarrow$ flux, Φ

Frictional coefficient, $B \rightarrow$ Conductance, $G = 1/R$

Mass, $M \rightarrow$ capacitance C

Stiffness, $K \rightarrow$ Inverse of inductance, $1/L$

Newton's second law \rightarrow Kirchhoff's current law.

20. Write the analogous electrical elements in torque voltage analogy for the elements of mechanical rotational system.

Torque, T à Voltage, e

Angular Velocity, ω à current, i

Angular Displacement, θ à charge, q

Frictional coefficient, B à Resistance, R

Moment of Inertia, J à inductance, L

Stiffness of the spring, K à Inverse of capacitance $1/C$

Newton's second law à kirchhoff's voltage law.

21. Write the analogous electrical elements in torque current analogy for the elements of mechanical rotational system.

Torque, T à current, i

Angular Velocity, ω à Voltage, e

Angular Displacement, θ à flux, Φ

Frictional coefficient, B à Conductance, $G = 1/R$

Moment of Inertia, J à capacitance C

Stiffness of the spring, K à Inverse of inductance, $1/L$

Newton's second law à kirchhoff's current law.

22. Write the force balance equation of an ideal mass, dashpot and spring element.

Let a force f be applied to an ideal mass M . The mass will offer an opposing force f_m which is proportional to acceleration.

$f_m = M \frac{d^2 X}{dt^2}$ Let a force f be applied to an ideal dashpot, with viscous frictional coefficient B . The dashpot will

offer an opposing force f_b which is proportional to velocity.

$$f = f_b = B \frac{dX}{dt}$$

Let a force f be applied to an ideal spring, with spring constant K . The spring will offer an opposing force f_k which is proportional to displacement.

$$f = f_k = K X$$

23. Why negative feedback is invariably preferred in closed loop system?

The negative feedback results in better stability in steady state and rejects any disturbance signals.

24. State the principles of homogeneity (or) superposition.

The principle of superposition and homogeneity states that if the system has responses $y_1(t)$ and $y_2(t)$ for the inputs $x_1(t)$ and $x_2(t)$ respectively then the system response to the linear combination of the individual outputs $a_1x_1(t) + a_2x_2(t)$ is given by linear combination of the individual outputs $a_1y_1(t) + a_2y_2(t)$, where a_1, a_2 are constant.

25. What are the basic properties of signal flow graph?

The basic properties of signal flow graph are

- Signal flow graph is applicable to linear systems.
- It consists of nodes and branches.
- A node adds the signal of all incoming branches and transmits this sum to all outgoing branches.
- Signals travel along branches only in the marked direction and is multiplied by the gain of the branch.
- The algebraic equations must be in the form of cause and effect relationship.

UNIT- II TIME RESPONSE

1. What is an order of a system?

The order of a system is the order of the differential equation governing the system. The order of the system can be obtained from the transfer function of the given system.

2. What is step signal?

The step signal is a signal whose value changes from zero to A at $t=0$ and remains constant at A for $t>0$.

3. What is ramp signal?

The ramp signal is a signal whose value increases linearly with time from an initial value of zero at $t=0$. The ramp signal resembles a constant velocity.

4. What is a parabolic signal?

The parabolic signal is a signal whose value varies as a square of time from an initial value of zero at $t=0$. This parabolic signal represents constant acceleration input to the signal.

5. What is transient response?

The transient response is the response of the system when the system changes from one state to another.

6. What is steady state response?

The steady state response is the response of the system when it approaches infinity.

7. Define Damping ratio.

Damping ratio is defined as the ratio of actual damping to critical Damping.

8. List the time domain specifications.

The time domain specifications are

- i. Delay time
- ii. Rise time
- iii. Peak time
- iv. Peak overshoot

9. What is damped frequency of oscillation?

In under damped system the response is damped oscillatory. The frequency of

damped oscillation is given by $\omega_d = \omega_n \sqrt{1 - \zeta}$

10. What will be the nature of response of second order system with different types of damping?

For undamped system the response is oscillatory.

For under damped system the response is damped oscillatory.

For critically damped system the response is exponentially rising.

For over damped system the response is exponentially rising but the rise time will be very large.

11. Define Delay time.

The time taken for response to reach 50% of final value for the very first time is delay time.

12. Define Rise time.

The time taken for response to raise from 0% to 100% for the very first time is rise time.

13. Define peak time

The time taken for the response to reach the peak value for the first time is peak time.

14. Define peak overshoot.

Peak overshoot is defined as the ratio of maximum peak value measured from the Maximum value to final value

15. Define Settling time.

Settling time is defined as the time taken by the response to reach and stay within specified error

16. What is the need for a controller?

The controller is provided to modify the error signal for better control action.

17. What are the different types of controllers?

The different types of the controller are

- Proportional controller
- PI controller
- PD controller
- PID controller

18. What is proportional controller?

It is device that produces a control signal which is proportional to the input error signal.

19. What is PI controller?

It is device that produces a control signal consisting of two terms –one proportional to error signal and the other proportional to the integral of error signal.

20. What is PD controller?

PD controller is a proportional plus derivative controller which produces an output signal consisting of two terms -one proportional to error signal and other proportional to the derivative of the signal.

21. What is the significance of integral controller and derivative controller in a PID controller?

The proportional controller stabilizes the gain but produces a steady state error. The integral control reduces or eliminates the steady state error.

22. Define Steady state error.

The steady state error is the value of error signal $e(t)$ when t tends to infinity.

23. What is the drawback of static coefficients?

The main drawback of static coefficient is that it does not show the variation of error with time and input should be standard input.

24. What are the three constants associated with a steady state error?

The three steady state errors constant are

- Positional error constant K_p
- Velocity error constant K_v
- Acceleration error constant K_a

25. What are the main advantages of generalized error co-efficients?

- i) Steady state is function of time.
- ii) Steady state can be determined from any type of input.

26. What are the effects of adding a zero to a system?

Adding a zero to a system results in pronounced early peak to system response thereby the peak overshoot increases appreciably.

27. Why derivative controller is not used in control system?

The derivative controller produces a control action based on rate of change of error signal and it does not produce corrective measures for any constant error. Hence derivative controller is not used in control system

28. What is the effect of PI controller on the system performance?

The PI controller increases the order of the system by one, which results in reducing the steady state error .But the system becomes less stable than the original system.

29. What is the effect of PD controller on system performance?

The effect of PD controller is to increase the damping ratio of the system and so the peak overshoot is reduced.

30. What is the disadvantage in proportional controller?

The disadvantage in proportional controller is that it produces a constant steady state error.

UNIT- III FREQUENCY RESPONSE

1. What is frequency response?

A frequency response is the steady state response of a system when the input to the system is a sinusoidal signal.

2. List out the different frequency domain specifications?

The frequency domain specifications are

- Resonant peak.
- Resonant frequency.
- Bandwidth
- Cut-off rate
- Gain margin

Phase margin

3. Define –resonant Peak

The maximum value of the magnitude of closed loop transfer function is called resonant peak.

4. What is bandwidth?

The bandwidth is the range of frequencies for which the system gain is more than 3 dB. The bandwidth is a measure of the ability of a feedback system to reproduce the input signal, noise rejection characteristics and rise time.

5. Define Cut-off rate?

The slope of the log-magnitude curve near the cut-off is called cut-off rate. The cut-off rate indicates the ability to distinguish the signal from noise.

6. Define –Gain Margin?

The gain margin, k_g is defined as the reciprocal of the magnitude of the open loop transfer function at phase cross over $G(j\omega_{pc})$ frequency. Gain margin $k_g = 1 / |G(j\omega_{pc})|$.

7. Define Phase cross over?

The frequency at which, the phase of open loop transfer functions is 180° is called phase cross over frequency ω_{pc} .

8. What is phase margin?

It is the amount of phase lag at the gain cross The phase margin, γ over frequency required to bring system to the verge of instability.

9. Define Gain cross over?

The gain cross over frequency ω_{gc} is the frequency at which the magnitude of the open loop transfer function is unity..

10. What is Bode plot?

The Bode plot is the frequency response plot of the transfer function of a system. A Bode plot consists of two graphs. One is the plot of magnitude of sinusoidal transfer function versus $\log \omega$. The other is a plot of the phase angle of a sinusoidal function versus $\log \omega$.

11. What are the main advantages of Bode plot?

The main advantages are:

- i) Multiplication of magnitude can be in to addition.
- ii) A simple method for sketching an approximate log curve is available.
- iii) It is based on asymptotic approximation. Such approximation is sufficient if rough information on the frequency response characteristic is needed.

is available. iv) The phase angle curves can be easily drawn if a template for the phase angle curve of $1 + j\omega$

12. Define Corner frequency?

The frequency at which the two asymptotic meet in a magnitude plot is called corner frequency.

13. Define Phase lag and phase lead?

A negative phase angle is called phase lag. A positive phase angle is called phase lead.

14. What are M circles?

The magnitude M of closed loop transfer function with unity feedback will be in the form of circle in complex plane for each constant value of M . The family of these circles are called M circles.

15. What is Nichols chart?

The chart consisting if M & N loci in the log magnitude versus phase diagram is called Nichols chart.

16. What are two contours of Nichols chart?

Nichols chart of M and N contours, superimposed on ordinary graph. The M contours are the magnitude of closed loop system in decibels and the N contours are the phase angle locus of closed loop system.

17. What is non-minimum phase transfer function?

A transfer function which has one or more zeros in the right half S-plane is known as nonminimal phase transfer function.

18. What are the advantages of Nichols chart?

The advantages are:

- i) It is used to find the closed loop frequency response from open loop frequency response.
- ii) Frequency domain specifications can be determined from Nichols chart.
- iii) The gain of the system can be adjusted to satisfy the given specification.

19. What are N circles?

If the phase of closed loop transfer function with unity feedback is α , then $N = \tan \alpha$. For each constant value of N, a circle can be drawn in the complex plane. The family of these circles are called N circles.

20. What are the two types of compensation?

The two types of compensation are

- i. Cascade or series compensation.
- ii. Feedback compensation or parallel compensation.

21. What are the three types of compensators?

The three types of compensators are

- i. Lag compensator.
- ii. Lead compensator.
- iii. Lag-Lead compensator.

22. What are the uses of lead compensator?

The uses of lead compensator are

- speeds up the transient response
- increases the margin of stability of a system
- increases the system error constant to a limited extent.

23. What is the use of lag compensator?

The lag compensator Improve the steady state behavior of a system, while nearly preserving its transient response.

24. When lag-lead compensator is is required?

The lag lead compensator is required when both the transient and steady state response of a system has to be improved

25. What is a compensator?

A device inserted into the system for the purpose of satisfying the specifications is called as a compensator.

26. When lag/lead/lag-lead compensation is employed?

Lag compensation is employed for a stable system for improvement in steady state performance. Lead compensation is employed for stable/unstable system for improvement in transient state performance.

Lag-Lead compensation is employed for stable/unstable system for improvement in both steady state and transient state performance

27. What are the effects of adding a zero to a system?

Adding a zero to a system results in pronounced early peak to system response thereby the peak overshoot increases appreciably.

UNIT – IV STABILITY AND COMPENSATOR DESIGN

1. Define stability.

A linear relaxed system is said to have BIBO stability if every bounded input results in a bounded output.

2. What is nyquist contour

The contour that encloses entire right half of S plane is called nyquist contour.

3. State Nyquist stability criterion.

If the Nyquist plot of the open loop transfer function $G(s)$ corresponding to the nyquist contour in the S-plane encircles the critical point $-1+j0$ in the contour in clockwise direction as many times as the number of right half S-plane poles of $G(s)$, the closed loop system is stable.

4. Define Relative stability

Relative stability is the degree of closeness of the system; it is an indication of strength or degree of stability.

5. What will be the nature of impulse response when the roots of characteristic equation are lying on imaginary axis?

If the root of characteristic equation lies on imaginary axis the nature of impulse response is oscillatory.

6. What is the relationship between Stability and coefficient of characteristic polynomial?

If the coefficient of characteristic polynomial are negative or zero, then some of the roots lie on the negative half of the S-plane. Hence the system is unstable. If the coefficients of the characteristic polynomial are positive and if no coefficient is zero then there is a possibility of the system to be stable provided all the roots are lying on the left half of the S-plane.

7. What is Routh stability criterion?

Routh criterion states that the necessary and sufficient condition for stability is that all of the elements in the first column of the routh array is positive. If this condition is not met, the system is

unstable and the number of sign changes in the elements of the first column of routh array corresponds to the number of roots of characteristic equation in the right half of the S-plane.

8. What is limitedly stable system?

For a bounded input signal if the output has constant amplitude oscillations, then the system may be stable or unstable under some limited constraints such a system is called limitedly stable system.

9. In routh array what conclusion you can make when there is a row of all zeros?

All zero rows in the routh array indicate the existence of an even polynomial as a factor of the given characteristic equation. The even polynomial may have roots on imaginary axis.

10. What is a principle of argument?

The principles of arguments states that let $F(S)$ are analytic function and if an arbitrary closed contour in a clockwise direction is chosen in the S-plane so that $F(S)$ is analytic at every point of the contour. Then the corresponding $F(S)$ plane contour mapped in the $F(S)$ plane will encircle the origin N times in the anti clockwise direction, where N is the difference between number of poles and zeros of $F(S)$ that are encircled by the chosen closed contour in the S-plane

11. What are the two segments of Nyquist contour?

- i. An finite line segment C_1 along the imaginary axis.
- ii. An arc C_2 of infinite radius.

12. What are root loci?

The path taken by the roots of the open loop transfer function when the loop gain is varied from 0 to infinity are called root loci.

13. What is a dominant pole?

The dominant pole is a pair of complex conjugate pole which decides the transient response of the system. In higher order systems the dominant poles are very close to origin and all other poles of the system are widely separated and so they have less effect on transient response of the system.

14. What are the main significances of root locus?

- i. The root locus technique is used for stability analysis.
- ii. Using root locus technique the range of values of K, for as stable system can be determined

15. What are break away and break in points?

At break away point the root locus breaks from the real axis to enter into the complex plane. At break in point the root locus enters the real axis from the complex plane. To find the break away or break in points, form a equation for K from the characteristic equation and differentiate the equation of K with respect to s. Then find the roots of the equation $dK/dS = 0$. The roots of

$dK/dS = 0$ are break away or break in points provided for this value of root the gain K should be positive and real.

16. What are asymptotes? How will you find angle of asymptotes?

Asymptotes are the straight lines which are parallel to root locus going to infinity and meet the root locus at infinity.

$$\text{Angles of asymptotes} = \pm 180^\circ(2q + 1)/(n-m) \quad q= 0,1,2, \dots\dots(n-m)$$

n-number of poles. m-number of zeros.

17. What is centroid?

The meeting point of the asymptotes with the real axis is called centroid. The centroid is given by

$$\text{Centroid} = (\text{sum of poles} - \text{sum of zeros}) / (n-m)$$

n-number of poles.

m-number of zeros.

18. What is magnitude criterion?

The magnitude criterion states that $s=s_a$ will be a point on root locus if for that value of S , magnitude of $G(S)H(S)$ is equal to 1.

$|G(S)H(S)| = K(\text{product of length of vectors from open loop zeros to the point } s=s_a) / (\text{product of length of vectors from open loop poles to the point } s=s_a) = 1.$

19. What is angle criterion?

The angle criterion states that $s=s_a$ will be the point on the root locus if for that value of S the argument or phase of $G(S)H(S)$ is equal to an odd multiple of 180° .

$(\text{Sum of the angles of vectors from zeros to the point } s=s_a) - (\text{Sum of the angles of vectors from poles to the point } s=s_a) = \pm 180^\circ(2q + 1)$

20. How will you find the root locus on real axis?

To find the root loci on real axis, choose the test point on real axis. If the total number of poles and zeros on the real axis to the right of this test point is odd number then the test point lie on the root locus. If it is even then the test point does not lie on the root locus.

21. What is characteristic equation?

The denominator polynomial of $C(S)/R(S)$ is the characteristic equation of the system.

22. How the roots of characteristic are related to stability?

If the root of characteristic equation has positive real part then the impulse response of the system is not bounded. Hence the system will be unstable. If the root has negative real parts then the impulse response is bounded. Hence the system will be stable.

23. What is the necessary condition for stability?

The necessary condition for stability is that all the coefficients of the characteristic polynomial be positive. The necessary and sufficient condition for stability is that all of the elements in the first column of the routh array should be positive.

24. What are the requirements for BIBO Stability?

The requirement of the BIBO stability is that the absolute integral of the impulse response of the system should take only the finite value.

25. What is auxiliary polynomial?

In the construction of Routh array a row of all zero indicates the existence of an even polynomial as a factor of given characteristic equation. In an even polynomial the exponents of S are even integers or zero only. This even polynomial factor is called auxiliary polynomial. The coefficients of auxiliary polynomial are given by the elements of the row just above the row of all zeros.

UNIT – V STATE VARIABLE ANALYSIS

1. Define state variable.

The state of a dynamical system is a minimal set of variables (known as state variables) such that the knowledge of these variables at $t=t_0$ together with the knowledge of the inputs for $t > t_0$, completely determines the behavior of the system for $t > t_0$.

2. Write the general form of state variable matrix.

The most general state-space representation of a linear system with m inputs, p outputs and n state variables is written in the following form:

$$\dot{X} = AX + BU$$

$$Y = CX + DU$$

Where X = state vector of order $n \times 1$.

U = input vector of order $n \times 1$.

A = System matrix of order $n \times n$.

B = Input matrix of order $n \times m$

C = output matrix of order $p \times n$

D = transmission matrix of order $p \times m$

3. Write the relationship between z-domain and s-domain.

All the poles lying in the left half of the S -plane, the system is stable in S -domain. Corresponding in Z -domain all poles lie within the unit circle. Type equation here.

4. What are the methods available for the stability analysis of sampled data control system?

The following three methods are available for the stability analysis of sampled data control system

1. Juri's stability test. 2. Bilinear transformation. 3. Root locus technique.

5. What is the necessary condition to be satisfied for design using state feedback?

The state feedback design requires arbitrary pole placements to achieve the desired performance. The necessary and sufficient condition to be satisfied for arbitrary pole placement is that the system is completely state controllable.

6. What is controllability?

A system is said to be completely state controllable if it is possible to transfer the system state from any initial state $X(t_0)$ at any other desired state $X(t)$, in specified finite time by a control vector $U(t)$.

7. What is observability?

A system is said to be completely observable if every state $X(t)$ can be completely identified by measurements of the output $Y(t)$ over a finite time interval.

8. Write the properties of state transition matrix.

The following are the properties of state transition matrix

- $\Phi(0) = e^{A \cdot 0} = I$ (unit matrix).
- $\Phi(t) = e^{A t} = (e^{-A t})^{-1} = [\Phi(-t)]^{-1}$.
- $\Phi(t_1 + t_2) = e^{A(t_1 + t_2)} = \Phi(t_1) \Phi(t_2) = \Phi(t_2) \Phi(t_1)$.

9. Define sampling theorem.

Sampling theorem states that a band limited continuous time signal with highest frequency f_m , hertz can be uniquely recovered from its samples provided that the sampling rate F_s is greater than or equal to $2f_m$ samples per second.

10. What is sampled data control system?

When the signal or information at any or some points in a system is in the form of discrete pulses, then the system is called discrete data system or sampled data system.

11. What is Nyquist rate?

The Sampling frequency equal to twice the highest frequency of the signal is called as Nyquist rate. $f_s = 2f_m$

12. What is similarity transformation?

The process of transforming a square matrix **A** to another similar matrix **B** by a -1 transformation $\mathbf{PAP} = \mathbf{B}$ is called similarity transformation. The matrix **P** is called transformation matrix.

13. What is meant by diagonalization?

The process of converting the system matrix **A** into a diagonal matrix by a similarity transformation using the modal matrix **M** is called diagonalization.

14. What is modal matrix?

The modal matrix is a matrix used to diagonalize the system matrix. It is also called diagonalization matrix.

If **A** = system matrix.

M = Modal matrix

M^{-1}
And $M^{-1}AM$ = inverse of modal matrix.

$M^{-1}AM$
Then $M^{-1}AM$ will be a diagonalized system matrix.

15. How the modal matrix is determined?

The modal matrix M can be formed from eigenvectors. Let $m_1, m_2, m_3 \dots m_n$ be the eigenvectors of the n^{th} order system. Now the modal matrix M is obtained by arranging all the eigenvectors column wise as shown below.

Modal matrix , $M = [m_1, m_2, m_3 \dots m_n]$.

16. What is the need for controllability test?

The controllability test is necessary to find the usefulness of a state variable. If the state variables are controllable then by controlling (i.e. varying) the state variables the desired outputs of the system are achieved.

17. What is the need for observability test?

The observability test is necessary to find whether the state variables are measurable or not. If the state variables are measurable then the state of the system can be determined by practical measurements of the state variables.

18. State the condition for controllability by Gilbert's method.

Case (i) when the eigen values are distinct

Consider the canonical form of state model shown below which is obtained by using the transformation $X=MZ$.

$$\dot{X} = \Lambda Z + U$$

$$Y = Z + DU$$

Where, $\Lambda = M^{-1}AM$; $C = CM^{-1}$, $D = M^{-1}B$ and M = Modal matrix.

In this case the necessary and sufficient condition for complete controllability is that, the matrix must have no row with all zeros. If any row of the matrix is zero then the corresponding state variable is uncontrollable.

Case(ii) when eigen values have multiplicity

In this case the state modal can be converted to Jordan canonical form shown below

$$\dot{X} = JZ + U$$

$$Y = Z + DU \quad \text{Where, } J = M^{-1}AM$$

In this case the system is completely controllable, if the elements of any row of that correspond to the last row of each Jordan block are not all zero.

19. State the condition for observability by Gilbert's method.

Consider the transformed canonical or Jordan canonical form of the state model shown below which is obtained by using the transformation, $X = MZ$

$$\dot{X} = AZ + U$$

$$Y = Z + DU \quad (\text{Or})$$

$$= JZ + U$$

$$Y = Z + DU \quad \text{where } D = CM \text{ and } M = \text{modal matrix.}$$

The necessary and sufficient condition for complete observability is that none of the columns of the matrix be zero. If any of the column is of has all zeros then the corresponding state variable is not observable.

20. State the duality between controllability and observability.

The concept of controllability and observability are dual concepts and it is proposed by kalman as principle of duality. The principle of duality states that a system is completely state controllable if and only if its dual system is completely state controllable if and only if its dual system is completely observable or viceversa.

21. What is the need for state observer?

In certain systems the state variables may not be available for measurement and feedback. In such situations we need to estimate the unmeasurable state variables from the knowledge of input and output. Hence a state observer is employed which estimates the state variables from the input and output of the system. The estimated state variable can be used for feedback to design the system by pole placement.

22. How will you find the transformation matrix, P_0 to transform the state model to observable phase variable form?

- Compute the composite matrix for observability, Q_0
- Determine the characteristic equation of the system $|\lambda I - A| = 0$.
- Using the coefficients a_1, a_2, \dots, a_{n-1} of characteristic equation form a matrix, W .
- Now the transformation matrix, P_0 is given by $P_0 = W Q_0^T$.

23. Write the observable phase variable form of state model.

The observable phase variable form of state model is given by the following equations

$$\dot{Z} = A_0 Z + B_0 u.$$

$$Y = C_0 Z + D u$$

Where, $A_0 = \begin{bmatrix} -a_{n-1} & 1 & 0 & \dots & 0 \\ 0 & -a_{n-2} & 1 & \dots & 0 \\ \vdots & \vdots & \vdots & \ddots & \vdots \\ 0 & 0 & \dots & 0 & -a_1 \end{bmatrix}$, $B_0 = \begin{bmatrix} 0 \\ 0 \\ \vdots \\ 0 \\ 1 \end{bmatrix}$ and $C_0 = [0 \ 0 \ \dots \ 0 \ 1]$

24. What is the pole placement by state feedback?

The pole placement by state feedback is a control system design technique, in which the state variables are used for feedback to achieve the desired closed loop poles.

25. How control system design is carried in state space?

In state space design of control system, any inner parameter or variable of a system are used for feedback to achieve the desired performance of the system. The performance of the system is related to the location of closed loop poles. Hence in state space design the closed loop poles are placed at the desired location by means of state feedback through an appropriate state feedback gain matrix, K .